

- [50] N. Bradshaw, E.F.H. Hall and N.E. Sanderson, *J. Anal. At. Spectrom.*, 4 (1989) 801.
- [51] M. Morita, H. Eto, T. Uehiro and K. Otsuka. *Anal. Sci.*, 5 (1989) 609.
- [52] S. Yamasaki, A. Tsumura and Y. Takaku, *Microchem. J.*, 49 (1994) 305.
- [53] U. Giebmann and U. Greb, *Fresenius J. Anal. Chem.*, 350 (1994) 186.
- [54] A.J. Walder and P.A. Freedman, *J. Anal. At. Spectrom.*, 7 (1992) 571.
- [55] A.J. Walder, A.I. Platzner and P.A. Freedman, *J. Anal. At. Spectrom.*, 8 (1993) 19.
- [56] J.N. Christensen, A.N. Halliday, D.C. Lee and C.M. Hall, *Earth Planet. Sci. Lett.*, 136 (1995) 79.
- [57] A.R. Date and A.L. Gray (Editors), *Applications of ICP-MS*, Blackie, Glasgow, 1989.
- [58] J.G. Crock and F.E. Lichte, *Anal. Chem.*, 54 (1982) 1329.
- [59] E. Cortes, *J. Radioanal. Nucl. Chem.*, 84 (1984) 157.
- [60] K. Govindaraju, *Geostand. Newsl.*, 8 (1984) Special Issue, Appendix 1, p. 1.
- [61] K. Govindaraju, *Geostand. Newsl.*, 13 (1989) Special Issue.

*Dr. V. Balaram received his doctorate degree in analytical chemistry in 1979 from the Andhra University, Visakhapatnam 530 003, India. He is now a senior scientist at the Geochemistry Division of the National Geophysical Research Institute, Hyderabad 500 007, India. His research interests include development of analytical methods for the determination of rare earth elements, precious metals and other elements in geological samples using AAS, ICP-AES and ICP-MS and application studies in geochemistry.*

## Electronic noses — development and future prospects

**M.A. Craven, J.W. Gardner\***  
Coventry, UK

**P.N. Bartlett**  
Southampton, UK

**The human olfactory system is still regarded as the most important 'analytical instrument' for the assurance of odour quality in many industries, such as food and drinks. Until recently, there has been no major advance in the analytical methods employed to assess odour. Now, research on artificial olfaction in the late 1980s and early 1990s has led to significant advances in this field and to the launch of commercial instruments (called 'electronic noses') being used in a variety of industries (including food, water and brewing). An electronic nose comprises an array of chemical sensors, where each sensor has only partial specificity to a wide range of odorant molecules, coupled with a suitable pattern recognition system. This paper briefly reviews the development of artificial**

**olfaction and discusses future trends in electronic nose technology.**

### 1. Anatomy of a smell

The main sensory system used by humans to sense flavour is olfaction, therefore if the flavour of a particular substance is to be characterized, the use of smell can often provide us with suitable information [1]. In order to understand the operation of an 'electronic nose' we must first analyse what is involved in 'smelling' and therefore what constitutes a 'smell', i.e., an odour. Odorant molecules have some basic characteristics, the primary ones being that they are light (relative molecular masses up to approximately 300 Da), small and polar and that they are often hydrophobic. A simple odour, for example an alcohol, contains only one chemical component. A complex odour is a mixture of many different odorant molecules each in varying concentration; for example, the headspace of coffee is made up of hundreds or even thousands of different molecules.

Table 1 shows the typical constituents of a coffee aroma. It is clear that we perceive coffee as having

\*Corresponding author.

Table 1  
Major constituents of coffee aroma by chemical class [ 1 ]

Class	Number	Class	Number
Furans	108	Oxazoles	28
Pyrazines	79	Thiazoles	27
Pyrroles	74	Thiophenes	26
Ketones	70	Amines	21
Phenols	44	Acids	20
Hydrocarbons	31	Alcohols	19
Esters	30	Pyridines	13
Aldehydes	28	Thiols/sulfides	13
		TOTAL	631

an easily distinguishable and unmistakable odour, but it has a complex odour with many constituents, each of which may change with time. Not only is the anatomy of a smell complex and subtle but the levels of odour that a panel of human experts can detect can be very low (e.g., sub-ppb).

Table 2 shows the threshold of odorant molecules in water that can be detected by a normal, healthy person. It can be seen that there is a wide range of values and that, in some cases, levels down to fractions of one part per billion can be detected. On the other hand, for compounds such as ethane, butane and acetylene, olfactory thresholds are much higher (parts per thousand). Attempting to detect complex odours containing components active at the very lowest levels by conventional analytical techniques was something that, until recently, was either very expensive or not feasible. It is therefore not surprising that traditional methods of odour assessment have survived for so long.

## 2. Human olfaction and the connection with electronic noses

Electronic nose research (a brief description of the history of electronic noses has been published previously [ 2 ]) is inspired by the mechanisms

Table 2  
Thresholds for various common odours [ 1 ]

Odour type	Threshold (in water)	Odour type	Threshold (in water)
Green leaves	0.32 ppm	Off-flavour in white fish	0.01 ppb
Rose	0.29 ppm	Green pepper	0.001 ppb
Thyme	86 ppb	Grapefruit	0.00002 ppb
Lemon	10 ppb		

involved in human olfaction. In recent years a greater understanding of human olfaction has been achieved [ 3,4 ] and this in turn has led to improvements in the design of an electronic nose. Fig. 1 illustrates the basic components of the human olfactory system and compares it with the construction of an electronic nose. The human olfaction system consists of three essential elements [ 5 ]: an array of olfactory receptor cells situated in the roof of the nasal cavity, the olfactory bulb which is situated just above the nasal cavity, and the brain. The electronic nose also has three roughly equivalent elements: the odour sensor array, data pre-processor, and pattern recognition (PARC) engine.

Fig. 2 shows how signals are mapped from the odour domain to the classification domain (the PARC engine includes the pre-processing stage in order to simplify the diagram). It can be seen here how odour 'A' is first shown as a vector in odour space where each dimension corresponds to the concentration of a single odorant molecule constituent, then as a vector in signal space where each dimension corresponds to the output from a single sensor in the sensor array and finally as a vector in classification space where each dimension corresponds to some arbitrary odour quality determined by the PARC engine. Although only two dimensions are shown in the diagram, the dimensionality of the vector that described odour 'A' reduces as it passes from one stage to another.

The odorant molecules from an object being smelt are inhaled through the nostrils and enter the nasal cavity. They then come into contact with the olfactory neurones located in the olfactory epithelium high up in the nose. These olfactory neurones are terminated in cilia (hairs) which lie in a thin, aqueous, mucous layer covering the epithelium. Special olfactory binding proteins located in these cell membranes interact with odorant molecules and cause excitation in the neurone. The number of different binding proteins is not known but has been estimated to be between 100

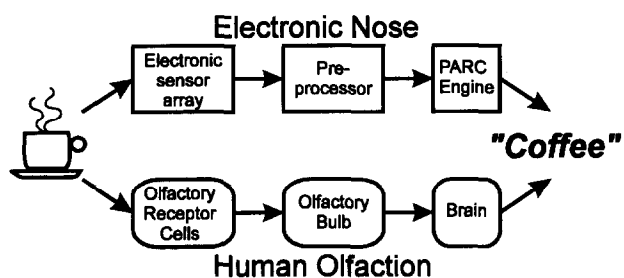

Fig. 1. Diagram showing the three basic elements that comprise an electronic nose and a human nose.

and 1000. Many olfactory neurones appear to express only one of the many possible olfactory binding proteins and, since the number of olfactory neurones is large (ca. 100 million), there is therefore a large population of olfactory neurones containing any given olfactory binding protein. The different olfactory binding proteins have partially overlapping sensitivities to odorants. For example, a particular olfactory neurone or set of neurones will respond to many different odorant molecules — they are not highly specific in their interactions. Similarly, an electronic nose employs a sensor array where each sensor is non-specific. Various sensor technologies are employed in electronic noses, the most popular ones that are now used in commercial instruments being semiconducting metal oxides (for example, catalytically doped tin oxide) and electronically conducting polymers. The former are sensitive to combustible gases, operate at high temperatures (e.g., 400°C) and use thick-film technology, whereas the latter respond to polar compounds, operate near room temperature, offer a large choice of types and are manufactured electrochemically. Fig. 3 shows photographs of two recently developed Warwick-Southampton microdevices: (a) a discrete device comprising a conducting polymer chemoresistor with a laterally integrated gold resistance heater on a TO-8 header and (b) a hex device (made at the Institute of Microtechnology, Neuchatel, Switzerland) comprising six MOS chemoresistors with vertically integrated platinum resistance heaters on a 0.1 inch pitch 14-pin d.i.l. header. The signals that form the output of a sensor array do not provide a spectrum of odour constituents in the way that, for example, a gas chromatograph does but rather information relating to the qualities of the odour which are characterized by particular sensor response signatures [3]. These signatures or artificial 'smellprints' can then be processed in a pattern

recognition engine and classified as smells (e.g., floral) in the artificial olfactory system [6].

The signals generated by the olfactory neurones feed into the olfactory bulb, which contains three functional layers: the glomeruli, the mitral cells and granular cell layer. The overall function of this stage is to reduce noise by compressing the signals and amplifying the output, this enhances both the sensitivity and selectivity of the olfactory system. Finally, the signals are processed into a form suitable for input to the brain where it is learnt and subsequently classified. Similarly, the pre-processing stage in the electronic nose processes the signals from the sensor array into a form suitable for input to the PARC (pattern recognition) stage. Factors such as sensor drift and noise can be reduced by pre-processing the signals; this has been shown elsewhere [7]. For example, a favourable choice of sensor parameter for an *n*-type MOS sensor is the fractional change in conductance  $G$ , where the output for one sensor (from an array of  $i$  sensors) for a particular odour type,  $j$ , is  $x_{ij}$ , which is given by

$$x_{ij} = (G_{\text{odour}} - G_{\text{air}}) / G_{\text{air}} \equiv (V_{\text{max}} - V_{\text{min}}) / V_{\text{max}} \quad (1)$$

Fig. 4 shows how the parameters  $V_{\text{max}}$  and  $V_{\text{min}}$  are defined from the transient response of a typical resistive odour sensor. This processing yields a vector of  $i$  dimensions for a given response to an odour, which is sometimes normalized so that concentration dependence is either eliminated (linear sensors) or reduced (non-linear sensors) and qualitative information is enhanced. In certain electronic nose applications it is necessary to know the odour intensity and so the norm of the array vector is used in the recognition system.

The final stage in the human olfactory process is the brain — it is here that odour classification takes place [3]. More specifically, the piriform cortex within the brain performs associative memory functions where olfactory cell response signatures are associated with notions of smells (although other areas of the brain such as the hippocampus are also involved). These associative functions have many properties:

- Similar patterns from the olfactory bulb can lead to vastly different outputs from the brain, i.e., chemically similar odours can be perceived as having very different qualities.
- Unknown inputs from the olfactory bulb are processed and the best solution is output from the brain; therefore, when a new and unknown

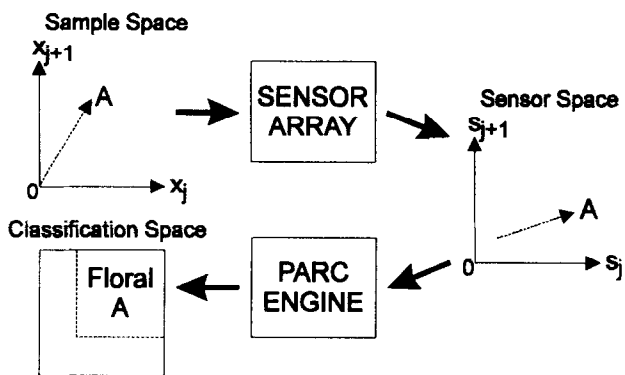

Fig. 2. Mapping of odours on to classification space in an electronic nose.

odour is encountered previous associations are used to give generalizations.

- New odours can be learnt throughout the lifetime of the subject, allowing adaptation to many environments.
- Changes in input signals from factors such as noise or olfactory cell regeneration (the olfactory cells regenerate every 30–40 days) do not cause large changes in the output from the brain due to the massively parallel and convergent system.

Similarly, artificial neural networks (ANNs) have been used in electronic noses in order to classify odours [ 7,8 ]. It has been found that the use of ANNs for pattern recognition show some benefits (such as being able to handle non-linear signals from the sensor array) when compared with the established multivariate chemometric techniques. The most popular type of ANN that is employed is the feed-forward multilayer perceptron (MLP) trained using the error-correction back-propagation algorithm (BP) [ 9 ]. Fig. 5 shows the typical layout of an MLP. Pattern recognition using a BP has two phases: first the MLP is trained using a data-set of sensor responses to known odours (training data-set) and second the MLP is tested on a different data-set of sensor responses to known odours (testing data-set). If, after training and testing, the performance of the MLP is satisfactory then the MLP design is finished. If, however, the performance is not satisfactory then a new MLP is designed using different network design parameters, such as the number of hidden nodes, node output function and training parameters and finally it is trained (again using the training data-set). The new MLP is tested (using the testing data-set) to ascertain if the performance is satisfactory. This whole process

can be repeated as many times as is necessary. Initial design parameters can be estimated to be at their optimum but in practice the exact value for

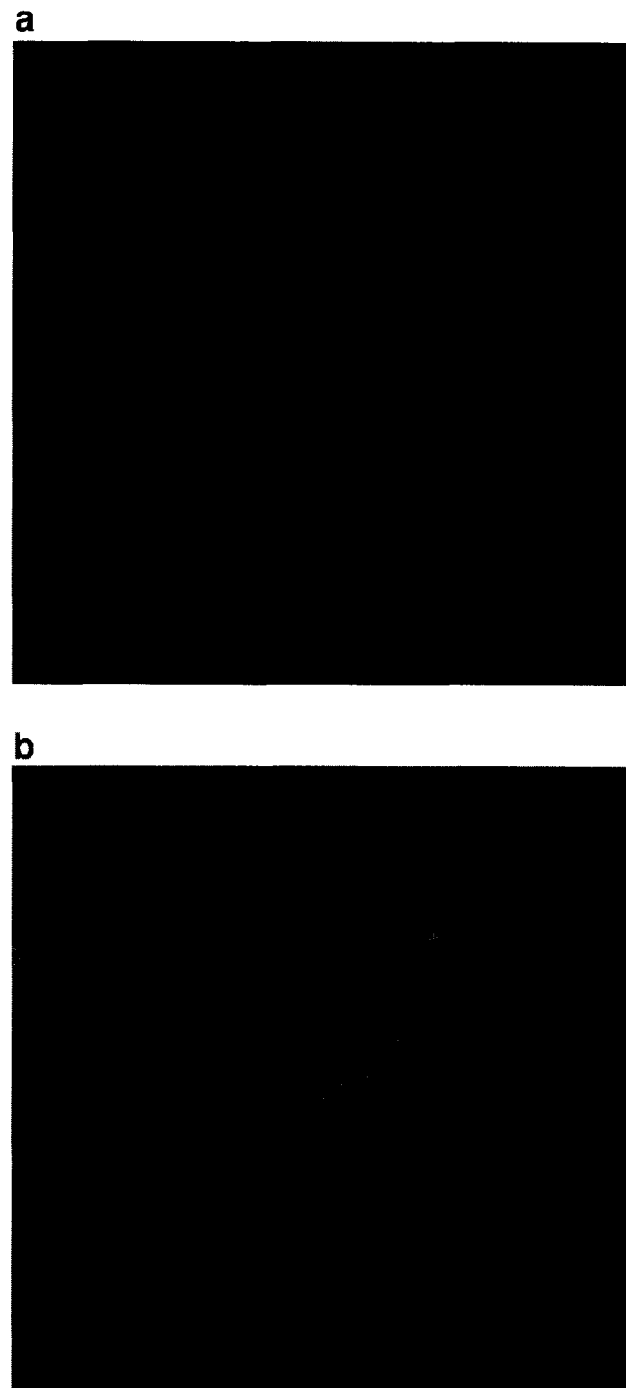

Fig. 3. Photographs of two Warwick-Southampton electronic odour sensors fabricated with microelectronic technology: (a) a discrete polymeric chemoresistor; (b) a hex metal oxide semiconducting MOS array device. Each device has integrated resistance heaters to control the operating temperatures of the odour-sensitive materials (indicated by small black areas).

these parameters is 'fine tuned' by experimentation. Once an MLP design has been found to be satisfactory for a particular set of odours it is possible that the same design will also be satisfactory for other similar problems.

BP is a simple training algorithm using gradient descent to minimize the error (i.e., difference between the desired output and the actual output). This training technique boosted interest in ANNs and has led to the application of ANNs in many industries. The basic principle employed in this training technique is that the error for a given input vector is propagated back to the hidden nodes in order for the weights input to the hidden nodes to be adjusted so that the error is minimized. Once the error has been minimized by an adjustment of hidden node input weights, the error is propagated back to the output nodes where the weights within the output nodes are adjusted so that the error is minimized. Once all the weights have been processed and the error is minimized the next input vector is input to the MLP and the corresponding output pattern is used for calculation of the error for this next input. This description of BP has been deliberately kept brief; however, several publications have discussed the topic in greater detail [9,10].

The parallel between human olfaction and machine olfaction (electronic nose) is often quoted and may be argued to be desirable certainly in function if not in the precise architecture [11].

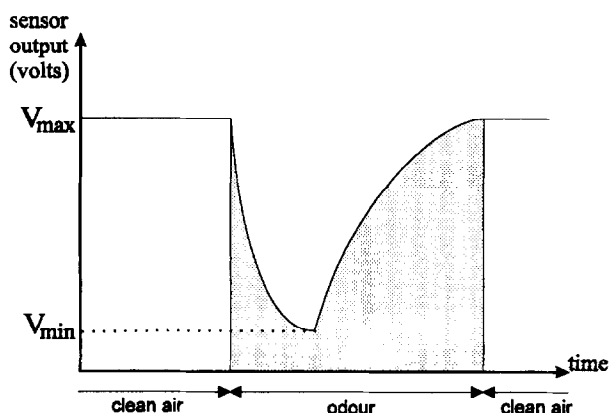

Fig. 4. Typical response of a MOS chemoresistive sensor to an odorant from a flow injection system. The voltage output is proportional to the device resistance so  $V_{max}$  is the baseline resistance and  $V_{min}$  the resistance in the odour.

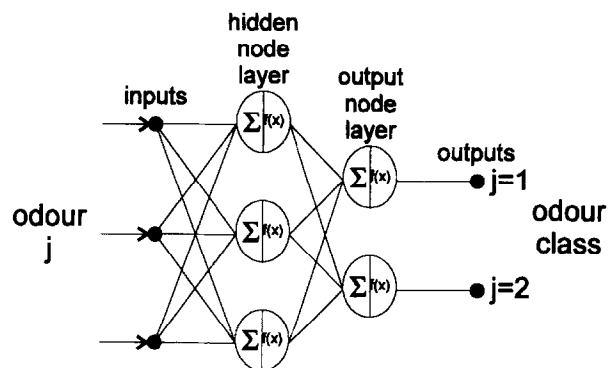

Fig. 5. General architecture of a feed-forward multi-layer perceptron, here with three hidden processing nodes, two output processing nodes, three inputs (sensor type  $i=1-3$ ) and two outputs (odour class  $j=1$  or  $2$ ). Each node performs a weighted sum of its inputs followed by a non-linear activation function on the result (usually sigmoid) and outputs a single value.

### 3. Odour analysis using an electronic nose

There are two main odour sampling methods: static headspace analysis (SHA) and flow injection analysis (FIA). SHA is the more popular and low-cost method, the sample to be 'smelt' is placed in a container, and left so that the headspace becomes saturated with the odour. This headspace is then transferred into the chamber containing the sensor array. The initial magnitude of response of the sensor array to the odour is large because the gas reaching the sensor array is saturated with the vapour, after a time the headspace is then removed from the chamber and replaced by clean air and the sensor responses return to their baseline values. The sensor response shown in Fig. 4 is a typical example of this. FIA is usually computer automated and employs a method where background gas (usually clean air) is constantly being pumped into the sensor chamber. Gas containing the odour is injected into the background gas before it reaches the sensor chamber. The ratio of the mixture of background gas to odour gas can be precisely controlled.

Unwanted variability in the data output from the sensor array is related to system complexity, a major factor being design and implementation of the sampling system. In order to optimize the cost of the electronic nose system, the sample/system variability must match the application:

- High variability—short-term process variation detector.
- Medium variability—triangular test, with quantitative similarity.
- Low variability—long-term odour standard for quality assurance

The lower the variability the more difficult the design, and therefore smell library construction is at the forefront of electronic nose research and application. It may be desirable to limit variation due to environmental factors, for example ambient air temperature where air is used as the carrier medium. However, in reality electronic noses need to operate in conditions that are not ideal such as outdoors where air temperature can vary greatly from day to day. Therefore, when factors causing variation cannot be controlled the design of the nose should permit their monitoring and on-line parametric compensation. This can be implemented in sensor array design through the use of, for example, a temperature sensor placed in the sensor chamber and temperature compensation in the sensor pre-processing and pattern recognition stages.

Visualizing the signal output from the sensor array and pre-processing stage often give clues to problems in electronic nose design, for example, if some or all of the types of sensors in the array are suitable. A popular method for visualizing signals is polar plots, in which the sensor responses are plotted radially around a circle. Fig. 6 shows two such polar plots, one for a sample of hardened canola oil and another for bleached soybean oil. From these plots the difference between the odours is apparent and the individual sensor responses can be isolated and analysed.

As mentioned earlier, ANNs are often employed as pattern classifiers in electronic noses [12,13]. However, it is also useful to use other methods in order to benchmark ANNs or to analyse the information contained in the data and from this to design more optimal pre-processing methods and ANNs. Examples of such multivariate pattern analysis techniques are

- Principal components analysis.
- Discriminant function analysis.
- Cluster analysis.

Fig. 7 shows a plot of the first linear discriminant function against the second for 12 replicate samples of six different types of sausage (labelled E1 to E6). The various groupings are easy to distinguish and tell us about the information content within the data, such as the presence of bias or noise. Various pattern recognition techniques can be used together or one technique can be used to analyse the data and permit the design of another.

#### 4. Why measure smells?

There are many potential applications for an electronic nose [14–17]; some of these are the checking of raw material, for example quality, taints and off-flavours; process monitoring, for example odour quality during processing; and product quality, for example of foods, drinks, perfumes, chemicals and pharmaceuticals.

Commercial electronic noses are only a recent phenomenon; their sales volumes are currently low (world market at about 200 in 1995) and their cost is relatively high (£20 000–£50 000).

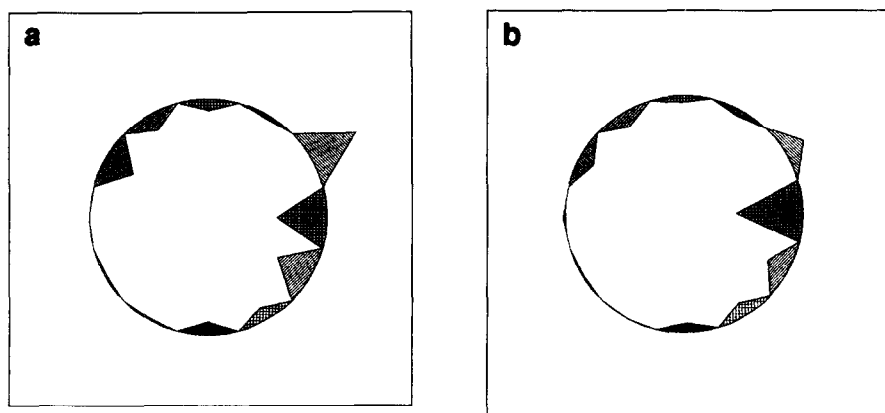

Fig. 6. Polar plots illustrating the response of a 12-element commercial polymer nose to the headspace of (a) hardened canola oil and (b) bleached soybean oil (Courtesy of Neotronics Scientific Ltd.). The response of each sensor in the electronic nose is plotted and so differences can be quickly seen.

The leading commercial instruments available are

- Aromascanner (Aromascan, UK)
- e-NOSE 4000 (Neotronics Scientific, UK)
- Fox Intelligent Nose (Alpha MOS, France)

The potential market for the electronic nose is large and the small volumes that are currently selling will increase as electronic nose technology improves. Also, production costs should fall as components such as the sensors themselves become cheaper to manufacture in larger volumes.

## 5. New developments in electronic nose technology

Improvement in electronic nose technology is important if its potential is to be realized. Possible improvements in technology are new odour-sensing materials, new transducers, multitype or hybrid noses, smarter pattern recognition techniques and micronoses.

New odour-sensing materials will need to be able to detect a wider range of odorant molecules and to be able to discriminate smaller details in odours. These materials could be newly developed semi-conducting oxides, conducting polymers, polymer/dielectric coatings, organic cage compounds or biological films. New transducers include piezoelectric (BAW and SAW) and catalytic gate MOS-FET devices (others are micropellistor and optoelectronic). Multitype (or hybrid) noses mix sensor and/or transducer technologies in order to increase the 'range' of the nose and enhance dis-

crimination. This leads to more complex interface electronics and signal pre-processing and possibly a more complex PARC. A 'smarter' electronic nose might employ more advanced ANN methods, for example methods even more closely related to biological neural systems like recurrent networks which oscillate in real time (as opposed to MLPs which are static). The advantages of a smarter nose could be

- Reduced sensitivity to temperature
- Reduced sensitivity to humidity
- Reduced interference to other gases
- Interference diagnostic
- Poisoning diagnostic

Because microelectronic devices are becoming cheaper and more powerful, the computing overhead that was such a barrier for ANN research in the past is no longer such a major problem and so the image of a 'smarter' nose may well soon be a reality. Problems such as sensor drift, noise and non-linearities in sensor response will be increasingly handled by the 'smarter' nose.

Lastly, the development of a 'micronose' will create new markets which are currently excluded by the large size and weight, cost and power consumption of the current laboratory-based instruments. A micronose will open up a whole new range of applications. Advances in silicon micro-machining techniques will mean that the sensor arrays will become miniaturized thus reducing size, power consumption, weight and cost. A micronose could be employed in situations where a human would not be able to go, for example inside

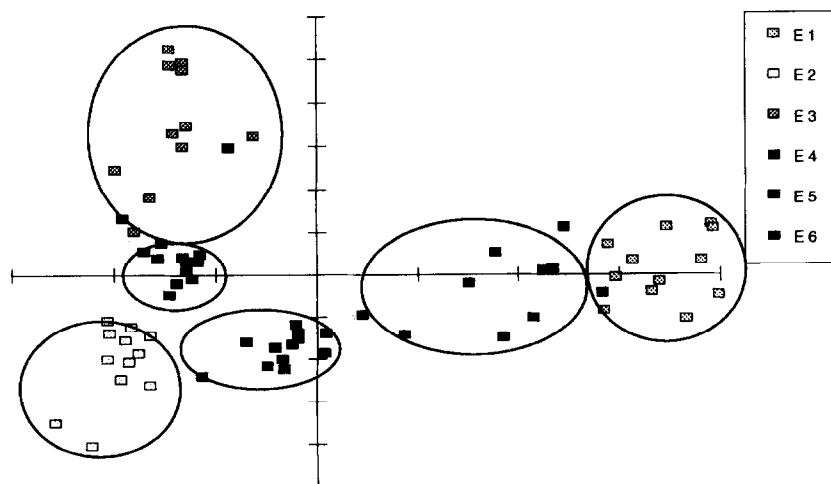

Fig. 7. Results from a linear discriminant function analysis of 12 replicate odours of six different types of sausage in a six-element MOS chemoresistive nose. The distance of the groups from each other indicates the chemical similarity of the odour. (Courtesy of Alpha MOS, France).

a human body. For many potential micronose applications only the sensor array need be miniaturized, the signals from the miniature sensor array could be transmitted over long distances, if necessary, in order that a more powerful (and therefore possibly not miniaturized) computer to be used to employ advanced and complex PARC techniques. The sensor signals could even be sent using an optical or wireless computer network.

As the applications for electronic noses become more complex and demanding, the emergence of application specific electronic noses (ASENs) will become more numerous. Possible applications are environmental, e.g., in buildings, cars and planes, biotechnology and medical diagnostics. The future for electronic noses looks very promising, so expect to see them in your home one day!

## References

- [ 1 ] G.H. Dodd, P.N. Bartlett and J.W. Gardner, in J.W. Gardner and P.N. Bartlett (Editors), *Sensors and Sensory Systems for an Electronic Nose*, NATO ASI Series E: Applied Sciences, Vol. 212, Kluwer, Dordrecht, 1992, Ch. 1.
- [ 2 ] J.W. Gardner and P.N. Bartlett, *Sens. Actuators B*, 18 (1994) 211.
- [ 3 ] D. Schild (Editor), *Chemosensory Information Processing*, NATO ASI Series H: Cell Biology, Vol. 39, Springer, Berlin, 1990.
- [ 4 ] M. Meredith, *Brain Res. Bull.*, 29 (1992) 111.
- [ 5 ] J.S. Kauer, *Trends Neurosci.*, 14 (1991) 79.
- [ 6 ] I. Lundstrom, *Nature*, 352 (1991) 47.
- [ 7 ] J.W. Gardner, E.L. Hines and H.C. Tang, *Sens. Actuators B*, 9 (1992) 9.
- [ 8 ] J.W. Gardner, E.L. Hines and M. Wilkinson, *Meas. Sci. Technol.*, 1 (1990) 446.
- [ 9 ] D.E. Rumelhart, G.E. Hinton and R.J. Williams, *Parallel Distributed Processing*, Vol. 1, MIT Press, 1986, pp 318–362.
- [ 10 ] R.P. Lippmann, *IEEE ASSP Mag.*, 4–22.
- [ 11 ] K. Persaud and G.H. Dodd, *Nature*, (1982) 352.
- [ 12 ] C.D. Natale, F. Davide and A. D'Amico, *Sens. Actuators B*, 23 (1995) 111.
- [ 13 ] J.W. Gardner, *Sens. Actuators B*, 4 (1991) 108.
- [ 14 ] J.W. Gardner, H.V. Shurmer and T.T. Tan, *Sens. Actuators B*, 6 (1992) 71.
- [ 15 ] L. Moy, T. Tan and J.W. Gardner, *Perfum. Flavorist*, 19 (1994) 11.
- [ 16 ] F. Winquist, E.G. Jornsten, H. Sundgren and I. Lundstrom, *Meas. Sci. Technol.*, 4 (1993) 1493.
- [ 17 ] T.C. Pearce, J.W. Gardner, S. Friel, P.N. Bartlett and N. Blair, *Analyst*, 118 (1993) 371.

*Mark Craven is at the Department of Engineering, University of Warwick, Coventry, CV4 7AL, UK. He graduated from Middlesex University in 1990 with a degree in electronic engineering. From 1990 to 1993 he worked at Consumer Microcircuits Ltd (based in Essex, UK) as an electronic engineer developing telecommunications products. Since 1993 he has been studying for a PhD at Warwick University. His research interests include the application of artificial intelligence to pattern recognition in electronic noses, medical applications of electronic noses and data processing algorithms applied to electronic nose signals.*

*Julian Gardner is at the Department of Engineering, University of Warwick, Coventry, CV4 7AL, UK. He graduated from Birmingham University in 1979 with a first class honours degree and then studied the properties of thin films at the Cavendish Laboratory for his PhD. From 1983 to 1987 he worked first at AEA Technology Ltd and later at Molins Advanced Technology Unit on instrumentation. Since joining Warwick as a Lecturer in 1987, his research interests have been sensor materials, the design of integrated gas array sensors and associated signal processing techniques. In 1989 he received the Esso Centenary Education Award sponsored by the Royal Society and Fellowship of Engineering to pursue his research interests. He was Director of an Advanced Research Workshop on Electronic Noses in 1991 and has published over 90 technical papers and 3 books. In 1992 he became a Senior Lecturer at Warwick and has recently been awarded an Alexander von Humboldt Fellowship in Germany. He currently holds a Personal Readership and is Director of the Sensors Research Laboratory in the Centre for Nanotechnology and Microengineering at Warwick University.*

*Philip Bartlett is at the Department of Chemistry, Southampton University, Southampton, SO17 1BJ, UK. He graduated from Oxford University in 1978 and then studied photoelectrochemistry at Imperial College, London, obtaining his PhD in 1981. From 1981 to 1984 he was a research assistant at Imperial College working on chemically modified electrodes. In 1984 he moved to the University of Warwick as a Lecturer in Physical Chemistry and then in 1991 to the University of Bath as Professor of Physical Chemistry. Since 1992 he has been a Professor of Chemistry and Head of the Electrochemistry sub-department at the University of Southampton. His research interests include conducting polymers, bioelectrochemistry and sensors. He has published over 90 papers on various aspects of electrochemistry.*