

Particle Identification

Graduate Student Lecture

Warwick Week

Outline

- Introduction
- Main techniques used for PID (Particle Identification):
 - *Cherenkov Detectors*
 - *Detectors using Energy Loss (dE/dx) from ionization and atomic excitation*
 - *Time of Flight (TOF) Detectors*
 - *Transition Radiation Detectors (TRD)*
- Summary
 - Not Covered : *PID using Calorimeters*
 - Cherenkov Detectors : *First part of the lecture*
 - *Focus on principles used in the detection methods.*

Introduction

- Particle Identification is a crucial part of several experiments in Particle Physics. Identify Pions, Kaons, Protons, electrons, muons, tau etc.
- Tracking+Magnet : Measure the direction and momentum of charged particles
- Calorimeter: Measure the energy deposited in an Electromagnetic or Hadronic shower created by the particles.
- PID: (a) Use information from Tracking and Calorimeters alone.
(b) Use additional information from 'Particle Identification' detectors .

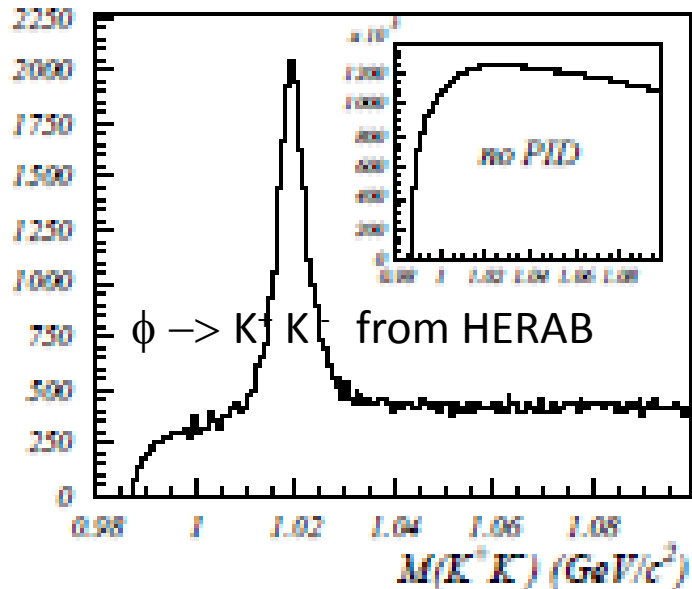

- 'PID' detector:
Reduction of combinatorial backgrounds
- More examples and other uses of PID detectors later in the lecture.

Cherenkov Detectors

- Cherenkov Radiation: General Ideas
- Brief History of the development of Cherenkov detectors
- Classification of Cherenkov detectors
- Photo detectors to detect Cherenkov Radiation
- Examples of large Cherenkov Detector systems

Basics of Cherenkov Radiation

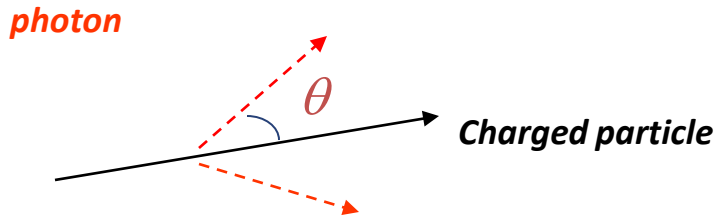

$$\cos(\theta) = 1 / (n \beta) \quad \text{where } n = \text{Refractive Index} = c/c_M = n(E_{\text{ph}})$$

$$\beta = v/c = p/E = p / (p^2 + m^2)^{0.5} = 1 / (1 + (m/p)^2)^{0.5}$$

β = velocity of the charged particle in units of speed of light (c) vacuum
 p, E, m = momentum, Energy, mass of the charged particle.
 c_M = Speed of light in the Medium (Phase velocity),
 E_{ph} = Photon Energy, λ = Photon Wavelength.

➤ Theory of Cherenkov Radiation: Classical Electrodynamics by J.D.Jackson (Section 13.5)

➤ The energy radiated by the charged particle as Cherenkov Radiation per unit length =

$$dE/dx = (Z/c)^2 \int_{\epsilon(\omega) > 1/\beta^2} \omega (1 - 1/(\beta^2 \epsilon(\omega))) d\omega$$

Where ω = Frequency

$\epsilon(\omega) = n^2$ = permittivity

assume permeability = 1

Z = charge of the particle

Typical example: Charged particle with momentum of few GeV/c or more emitting Cherenkov photons with few eV of energy

Basics of Cherenkov Radiation

$$\cos(\theta) = 1 / (n \beta)$$

$\theta = 0$: Cherenkov Threshold for the charged particle. At Threshold, $\beta = 1/n$

θ has Maximum in a medium when β almost = 1 \Leftrightarrow p/m sufficiently high \Leftrightarrow Saturated Tracks

- Particle ID: $\theta (p, m)$; If we measure p and θ , we can Identify different particles with different m .
- Typically, in Accelerator based experiments, Momentum (p) is measured by a Magnetic Spectrometer : Tracking detectors and a Magnet.
- Cherenkov Detectors: Measure θ : Resolution can be expressed in terms of $(\Delta \beta / \beta)$

Photonic Crystals: No Cherenkov Threshold and $\theta > 90$ degree.

Not covered in this lecture: Reference: <http://ab-initio.mit.edu/photons>

Basics of Cherenkov Radiation

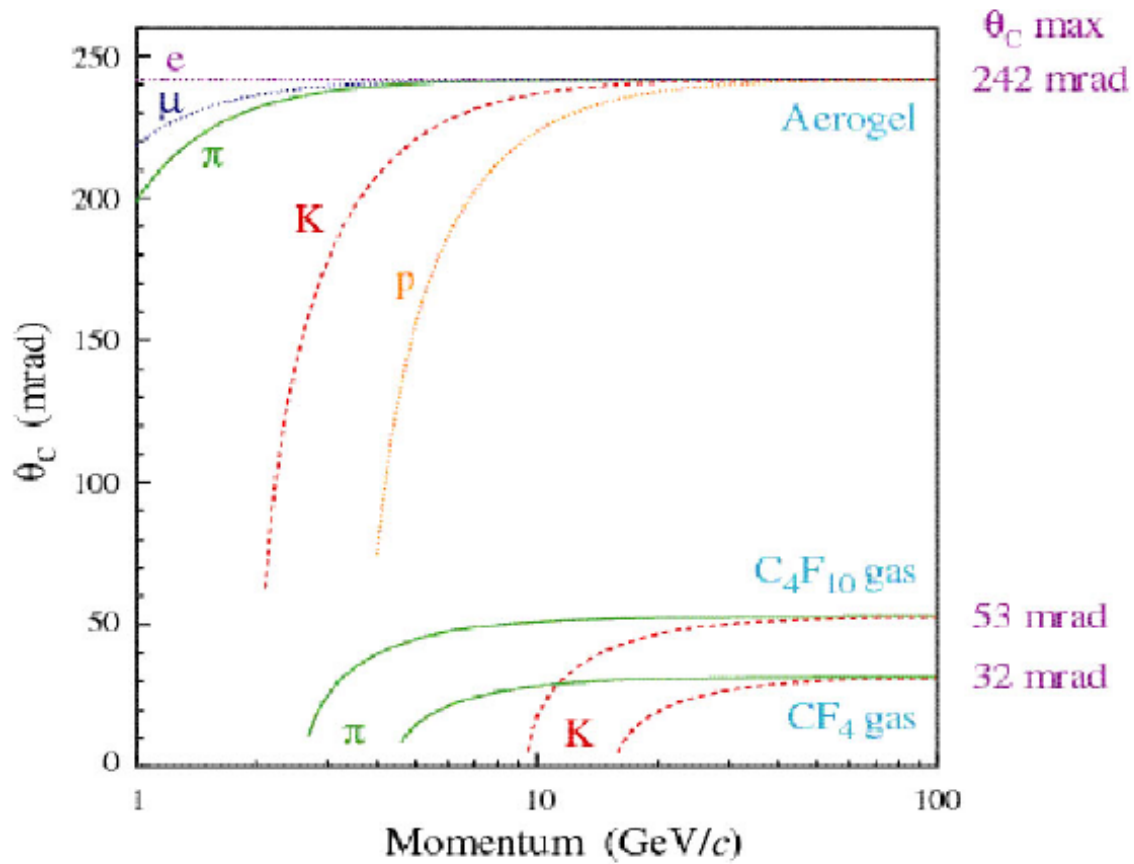

Cherenkov Angle vs Charged Particle Momentum

Components of a Cherenkov Detector

- Main Components:
 - Radiator : To produce photons
 - Mirror/lens etc. : To help with the transport of photons
 - Photodetector : To detect the photons

➤ Radiator: Any medium with a Refractive Index.

Example of radiators

Medium	n-1	γ_{th}	Photons/m
He (STP)	$3.5 \cdot 10^{-5}$	120	3
CO ₂ (STP)	$4.1 \cdot 10^{-4}$	35	40
Silica aerogel	0.025-0.075	4.6-2.7	2400-6600
water	0.33	1.52	21300
Glass	0.46-0.75	1.37-1.22	26100-33100

Aerogel: network of SiO₂ nano-crystals

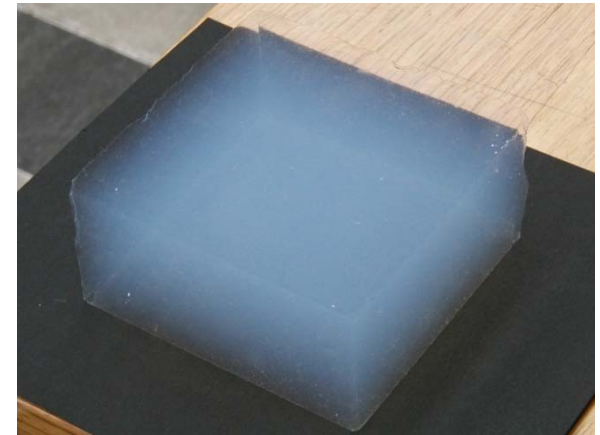

$$\gamma = 1/\sqrt{1-\beta^2}$$

➤ The atmosphere, ocean are the radiators in some Astro Particle Cherenkov Detectors

Note on the History of Cherenkov Radiation

- The formula $\cos(\theta) = 1/(n\beta)$ was already predicted by Heaviside in 1888
- ~1900: 'Blue glow' seen in fluids containing concentrated Radium (Marie & Pierre Curie)
- Pavel Alexeevich Cherenkov (1904-1990): Lebedev Physical Institute of the Russian Academy of Sciences.
- Discovery and Validation of Cherenkov Effect : 1934-37
- Full Explanation using Maxwell's equations: I.M. Frank and I.E. Tamm in 1937
- Nobel Prize in 1958: Cherenkov, Frank and Tamm.

History of Cherenkov Radiation

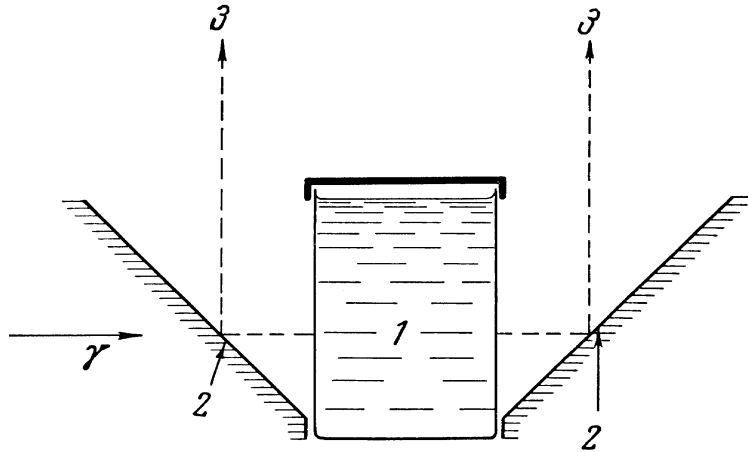

- 1: vessel with liquid
- 2 mirror
- 3: Cherenkov photons towards the photographic plate

Typical Apparatus used by Cherenkov to study the angular distribution of Cherenkov photons. (Incident γ ray produces electrons by Compton scattering in the liquid).

P. Cherenkov established that:

- Light Intensity is proportional to the electron path length in the medium.
- Light comes only from the 'fast' electrons above a velocity threshold, in his Apparatus.
- Light emission is prompt and the light is polarized.
- The wavelength spectrum of the light produced is continuous. No special spectral lines.
- The angular distribution of the radiation, its intensity, wavelength spectrum and its dependence on the refractive index agree with the theory proposed by his colleagues Frank and Tamm.

Photons from Cherenkov Radiation

- $n = n(\lambda)$: Different photons from the same charged track can have different Cherenkov Angles. ($\cos(\theta) = 1/n\beta$).
- This spread in angles gives rise to 'Chromatic Error' when measuring the average θ .

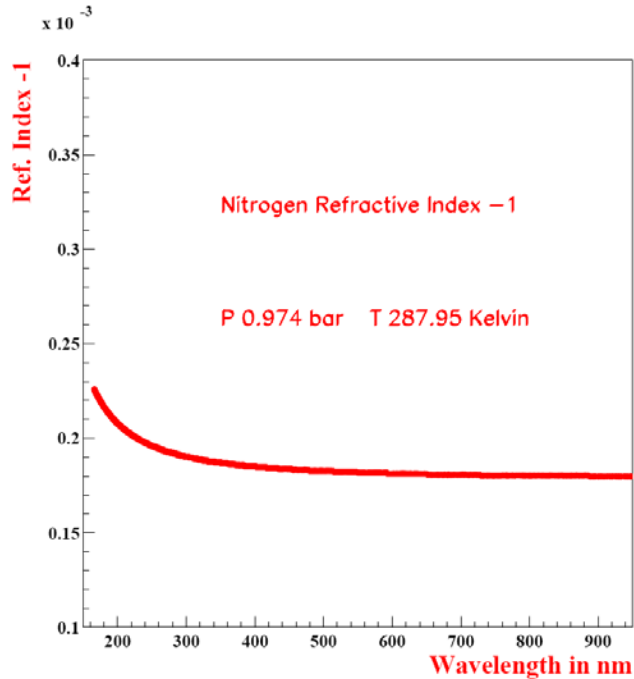

- To reduce the Chromatic error various methods have been tried:
- Filter out the low wavelength photons before they reach the photodetector.
 - Appropriate choice of the radiator material
 - **Recent development:** Measure the Time-Of-Propagation of photons to estimate their wavelengths and correct for the Chromatic Error. ($\text{Time} = (\text{PathLength in the detector}) / \text{Velocity}$)

Photons from Cherenkov Radiation

- Current photon detectors used for detecting Cherenkov light are sensitive to visible + part of UV. This part of the EM spectrum produced by the Cherenkov Radiation is the only range relevant for Cherenkov detectors. λ_{ph} ranges from 135 nm to 800 nm depending upon the photodetector.

- Number of photons produced by a particle with charge Z , along a Length L : (From Frank-Tamm theory)

$$N_{prod} = (\alpha/hc) Z^2 L \int \sin^2(\theta) dE_{ph} \quad \text{where} \quad \alpha/hc = 370 \text{ eV}^{-1}\text{cm}^{-1}, E_{ph} = hc/\lambda.$$

- If the photons are reflected by a Mirror with Reflectivity $R(E_{ph})$, are transmitted through a quartz window of Transmission $T(E_{ph})$ and then are detected by a photon detector with efficiency $Q(E_{ph})$

- Number of photons detected :

$$N_{det} = (\alpha/hc) Z^2 L \int R Q T \sin^2(\theta) dE_{ph}$$

$$= N_0 L \sin^2(\theta_c) \quad (\text{If we assume } \theta \text{ is constant} = \theta_c = \text{Mean Cherenkov Angle})$$

- Figure of Merit of the detector = N_0 For example, $N_0 = 200 \text{ cm}^{-1}$ is a good value.

Classification of Cherenkov Detectors

➤ Cherenkov Detector Designs:

- Threshold Counters

- Imaging Counters:
 - Differential Cherenkov Detectors
 - Ring Imaging Cherenkov Detectors (RICH)
 - Detector for Internally Reflected light (DIRC)

➤ Types of Photodetectors: (a) Gas Based (b) Vacuum Based (c) Solid State

- Applications:
 - In Accelerator Based High Energy Physics Detectors
 - In AstroParticle Physics Detectors

Differential Cherenkov Detectors

With Solid (quartz) radiator

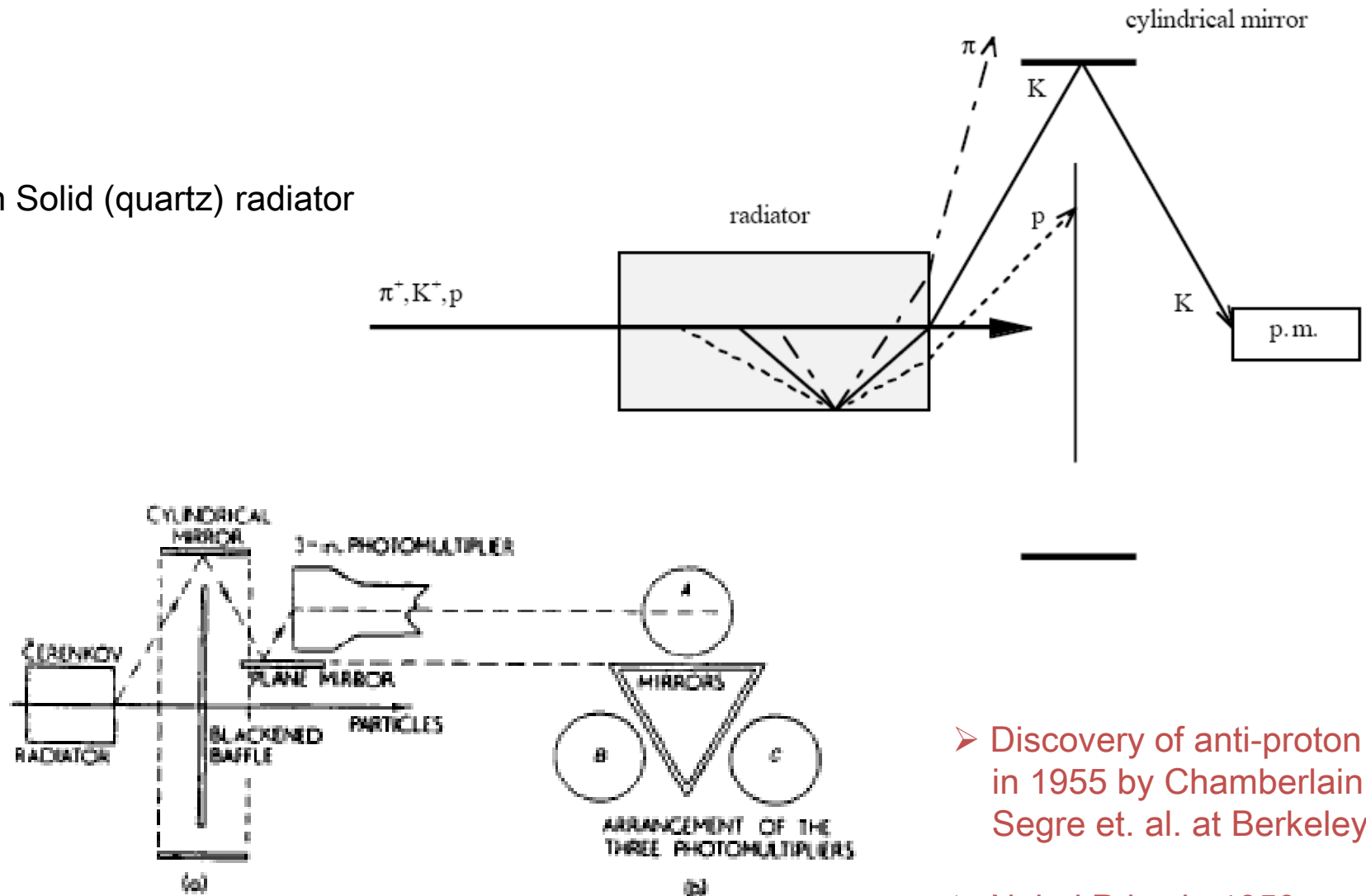

➤ Discovery of anti-proton in 1955 by Chamberlain, Segre et. al. at Berkeley.

➤ Nobel Prize in 1959

Fig. 2. The differential Cherenkov counter used in the anti-proton discovery experiment: (a) side view; (b) end view.

Differential Cherenkov Detectors

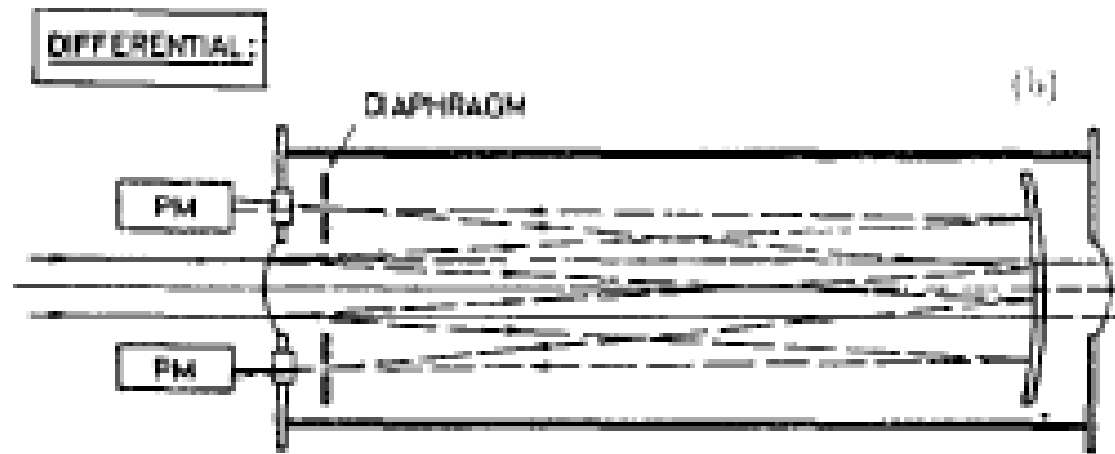

With a Gas radiator

Table 2
Some differential Cherenkov counters

Type	Year	Length [m]	Angle [mrad]	Gas	Range for $(\pi-K)$ [GeV/c]	Remarks	Ref.
IHEP [1]	1968	5	23	He, N ₂	< 100	no optical correction	[3]
[2]		10	12		< 200		
DISC	1964	2	44	CO ₂	< 100	corrected	[4]
FNAL DISC	1973	5.5	25	He	< 500	Id.	[2]
					(< 100 for $\pi-\mu-e$)		
CEDAR W	1976	3.25	31	N ₂	< 150	Id	[5]
N		3.90	26	He	< 340		
HYPERON DISC	1972	0.3	120	SF ₆	< 40	Id.	[2]
					(< 100 for $\Sigma-p$)		
For comparison: LDISC	1976	0.05	640	FC88 liquid	< 5	corrected high aperture	[6]

Differential Cherenkov Detectors

- Very small acceptance in β and direction of the charged particle. (Narrow range in velocity and direction intervals).
- From the Cherenkov angle (θ) determine β .
- Mostly used for identifying particles in the beam lines.
- Resolution that can be achieved = $\Delta \beta / \beta = (m_1^2 - m_2^2) / 2 p^2 = \tan \theta \Delta \theta$
 m_1, m_2 (particle masses) $\ll p$ (momentum)
- At high momentum, to get better resolution, use gas radiators which have smaller refractive index than solid radiators. Have long enough radiators to get sufficient signal photons in the detector.
- To compensate for Chromatic dispersion ($n(E_{ph})$), lens used in the path of the photons. (DISC: Differential Isochronous self-collimating Cherenkov Counter).
- $\Delta \beta / \beta$ from 0.011 to $4 \cdot 10^{-6}$ achieved.

Threshold Cherenkov Counters

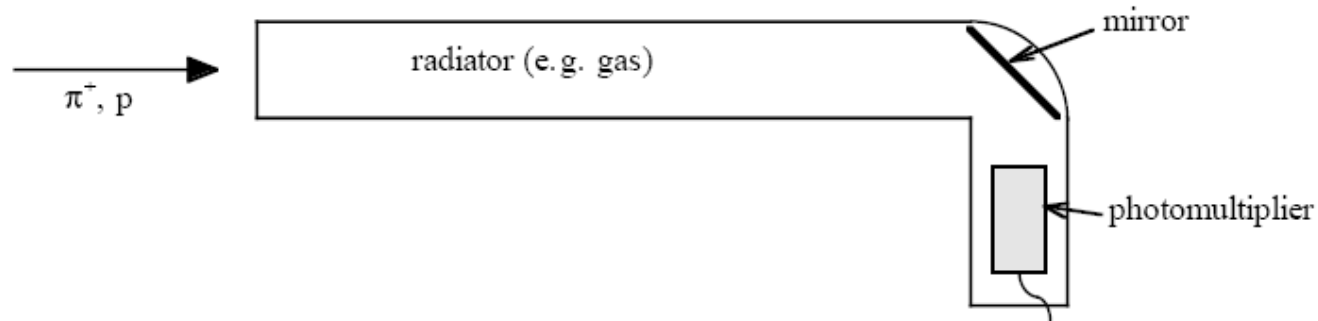

- Signal produced from only those particles which are above Cherenkov Threshold.
Basic version: Yes/No decision on the existence of the particle type.
- One counts the number of photoelectrons detected.
- Improved version: Use the number of observed photoelectrons or a calibrated pulse height to discriminate between particle types.
- For typical detectors: $N_o = 90 \text{ cm}^{-1}$,

$$N_{\text{ph}} \text{ per unit length of the radiator} = N_o * (m_1^2 - m_2^2)/(p^2 + m_1^2)$$

At $p = 1 \text{ GeV}/c$, N_{ph} per unit length = 16 /cm for Pions and 0 for Kaons.

At $p = 5 \text{ GeV}/c$, N_{ph} per unit length = 0.8 /cm for Pions and 0 for Kaons.

- $\Delta \beta / \beta = \tan^2 \theta / (2 * \text{sqrt}(N_{\text{ph}}))$

Threshold Cherenkov Detectors

- Can be used over a large area, for Example : For secondary particles in a fixed target or Collider experiment.
- E691 at Fermilab: To study decays of charm particles in the 1980's
 $\Delta\beta/\beta = 2.3 * 10^{-5}$ using gas radiator.
- BELLE Experiment: To observe CP violation in B-meson decays at an electron-positron collider.

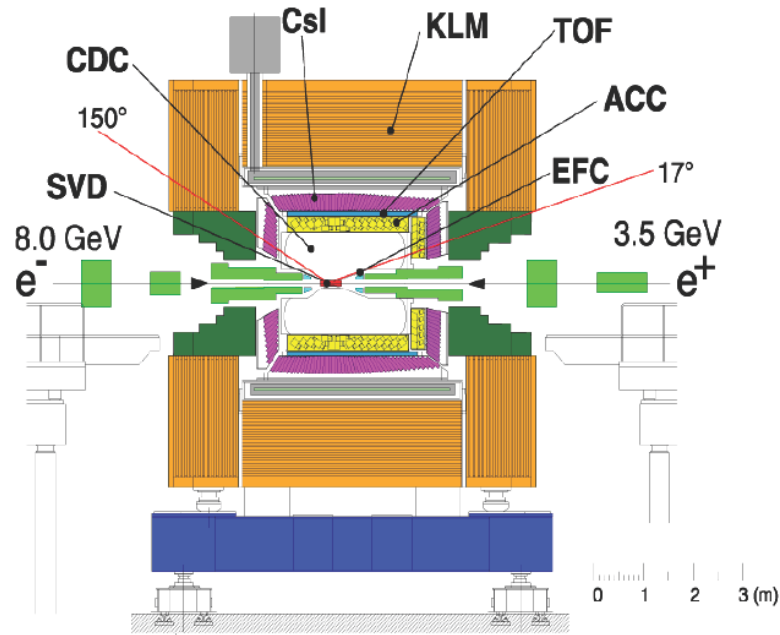

- BELLE: Continues to take Data.

Threshold Counters

BELLE: Threshold Cherenkov Detector

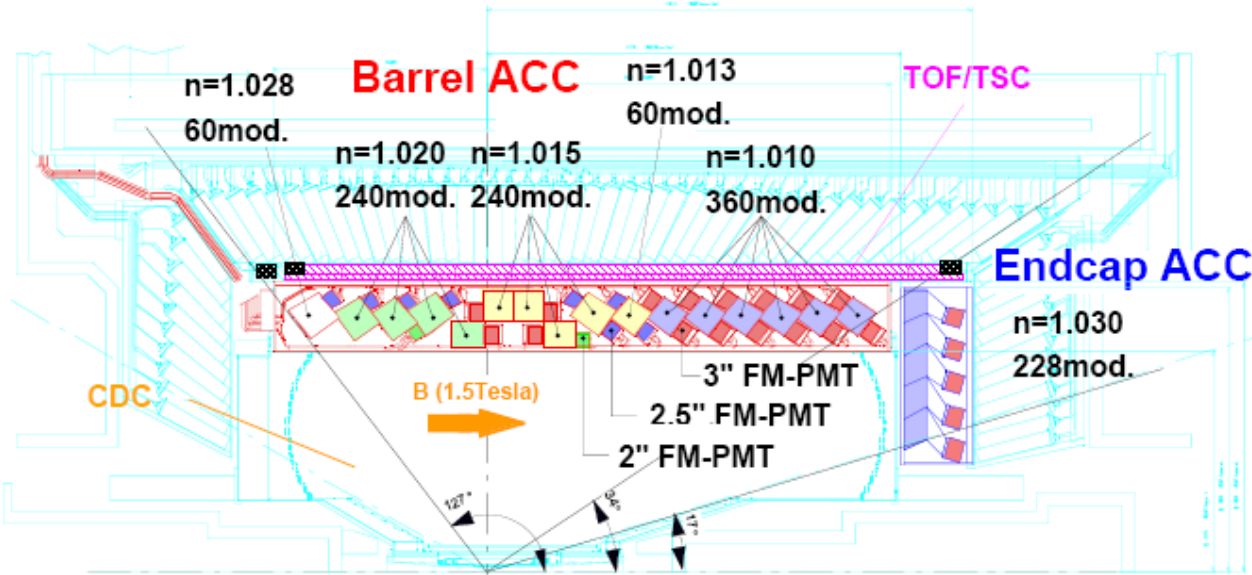

- Five aerogel tiles inside an aluminum box lined with a white reflector (Goretex reflector)
- Performance from test-beam

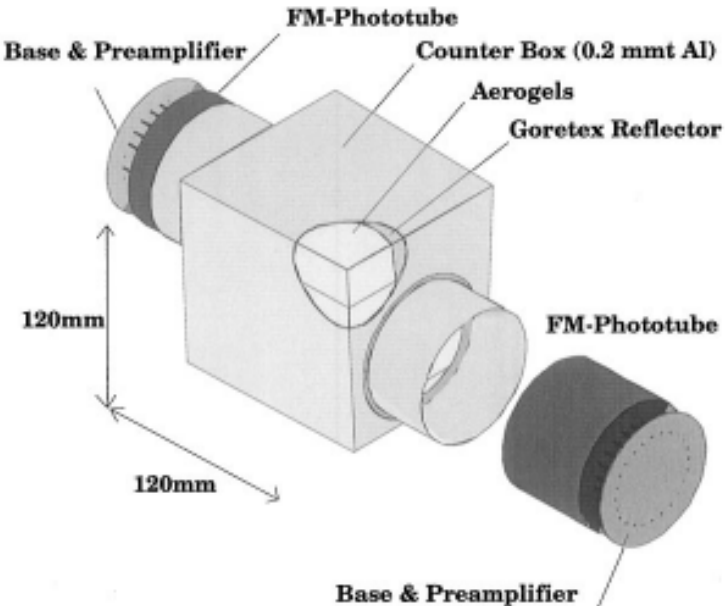

- Approx . 20 photoelectrons per Pion detected at 3.5 GeV/c
- More than 3σ separation

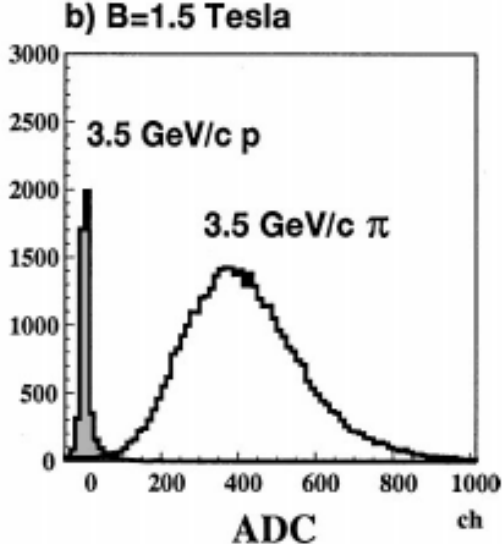

p below and π above Threshold

RICH Detectors

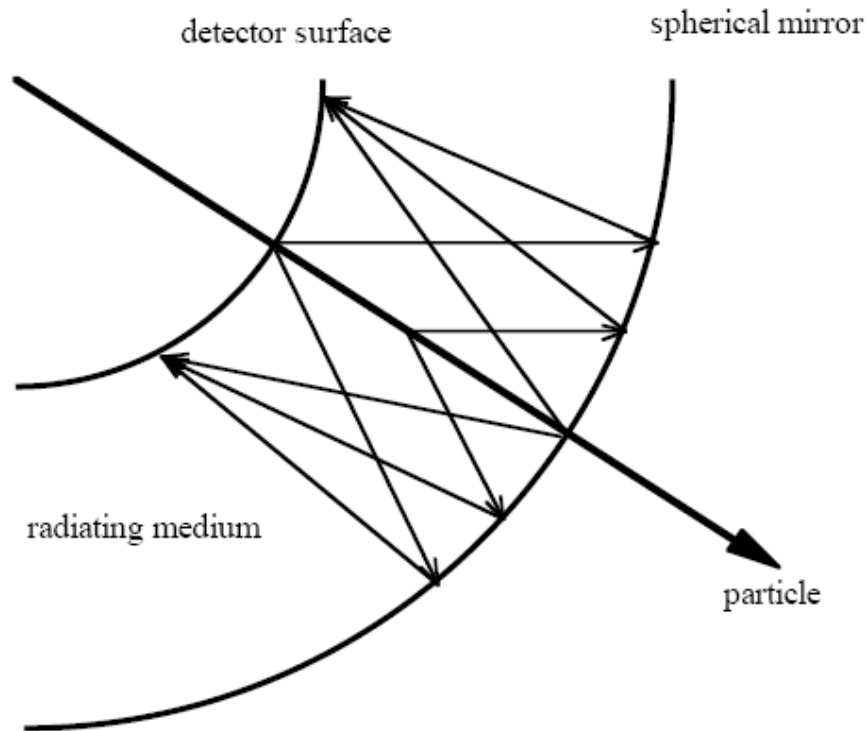

- Measures both the Cherenkov angle and the number of photoelectrons detected.
- Can be used over particle identification over large surfaces.
- Requires photodetectors with single photon identification capability.

RICH detectors

➤ $\Delta \beta / \beta = \tan(\theta) * \Delta \theta_c = K$ where $\Delta \theta_c = \langle \Delta \theta \rangle / \sqrt{N_{ph}} + C$

where $\langle \Delta \theta \rangle$ is the mean resolution per single photon in a ring and C is the error contribution from the tracking, alignment etc.

➤ For example, for 1.4 m long CF_4 gas radiator at STP and a detector with $N_0 = 75 \text{ cm}^{-1}$
 $K = 1.6 * 10^{-6}$. ($E=6.5 \text{ eV}$, $\Delta E = 1 \text{ eV}$)

- This is better than similar Threshold counters by a factor 125.
 This is also better than similar Differential counters by a factor 2.
 Reason: RICH measures both θ and N_{ph} directly.

➤ RICH detectors have better resolution than equivalent Differential and Threshold counters.

➤ Let $u = \sin^2(\theta) = 1 - (1/n^2) - (m/p*n)^2$

Number of standard deviations to discriminate between mass m_1 and m_2

$= N_\sigma = (u_2 - u_1) / (\sigma_u * \sqrt{N})$ where σ_u : $\Delta \theta$ converted into the parameter u.
 ($\Delta \theta$ = error in single photon θ measurement)

➤ At momentum p ($=\beta E$), $p = \sqrt{((m_2^2 - m_1^2) / (2 * K * N_\sigma))}$, for $\beta \sim 1$

This equation can be used in the design of the RICH detectors.

➤ One the first large size RICH detector: in DELPHI at LEP.

Detection of Photoelectrons

- Principle:
 - Convert Photons → Photoelectrons using a photocathode
 - Detect these photoelectrons using 'charged track detectors'.
 - Measure the position and (/or) time of photoelectrons in the tracking detector.
- General introduction to tracking detectors is not covered in this lecture.
Introduction to Silicon detectors already covered in another lecture of this series.
- In this lecture, we focus on some of the aspects related to the detection of photoelectrons in Cherenkov Detectors.
- Gas based detectors:
 - MWPC (Multi Wire Proportional Chambers)
 - GEM (Gas Electron Multiplier)
- Vacuum based detectors: PMT (Photomultiplier tubes)
HPD (Hybrid Photodiodes)
- Solid state detectors: Silicon photomultipliers

Photodetectors

➤ Photon Conversion:

- Photoelectric Effect : Photon energy to be above the 'work function' (**Einstein : Nobel Prize in 1921**).
- Commercial alkaline Photocathodes: Bialkali , Trialkali (S20) , CsI etc. Alkali metals have relatively low 'work function'.
- There are also gases where the photon conversion takes place.
- Different photocathodes are efficient at different wavelength ranges.
- Quantum Efficiency (QE) : Fraction of photons converted to electrons

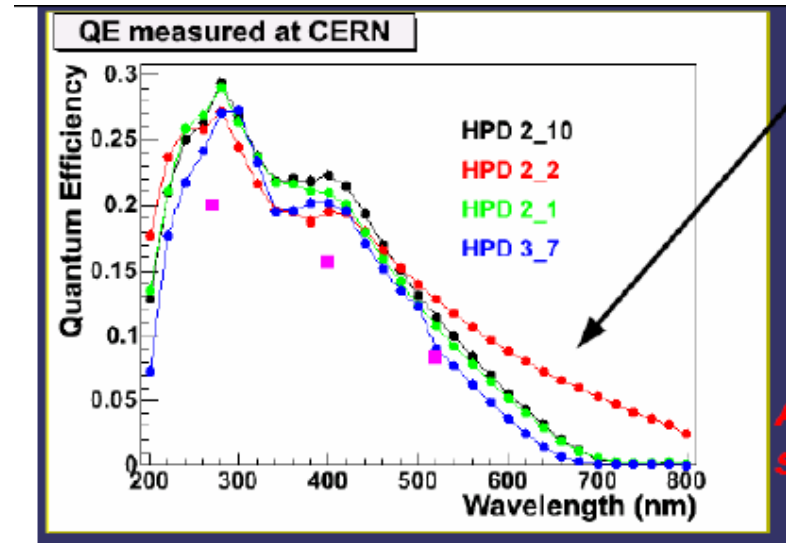
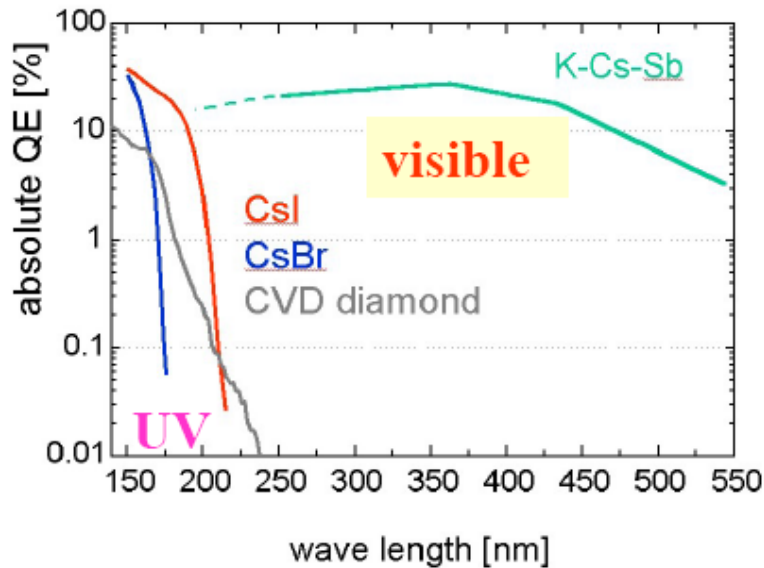

Examples of S20- photocathodes

Gas Based Photon Detectors

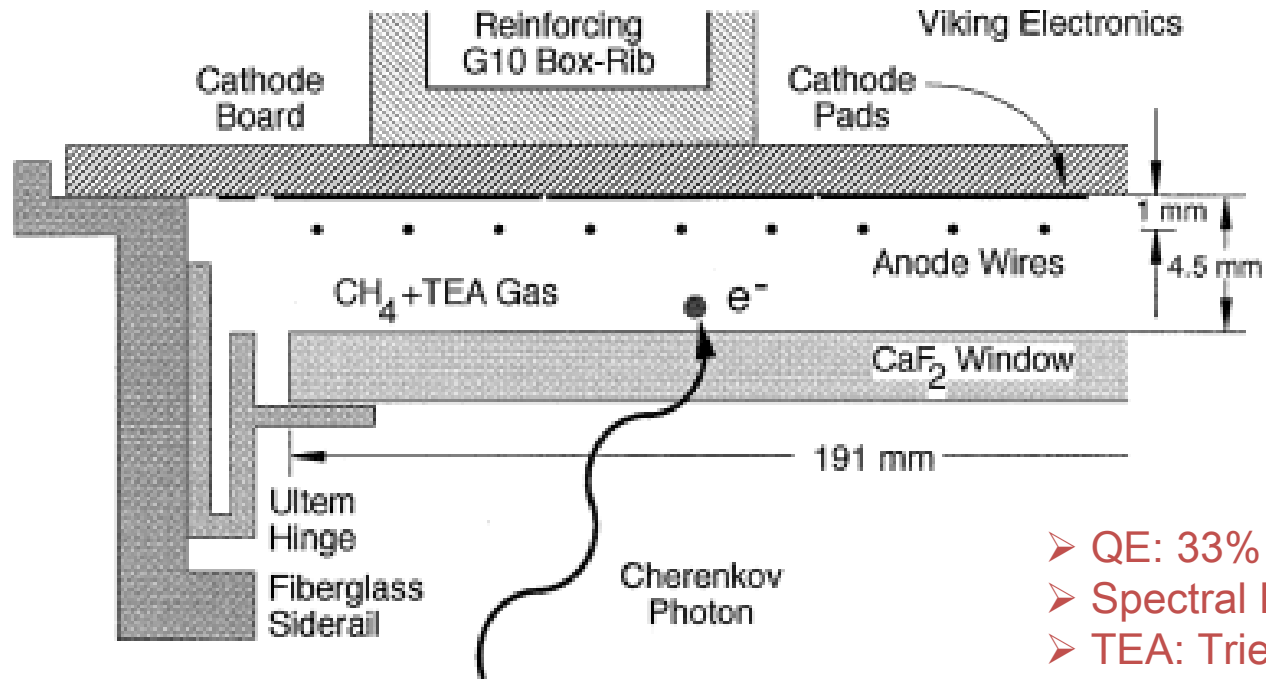

Photon Detector of the CLEO-III Cherenkov detector

- photon passes through the CaF_2 and converts to photoelectron by ionizing a TEA molecule.
- The photoelectron drifts towards and avalanches near the anode wires, thereby inducing a charge signal on the cathode pads.

Balloon Experiment: RICH detector

CAPRICE Experiment

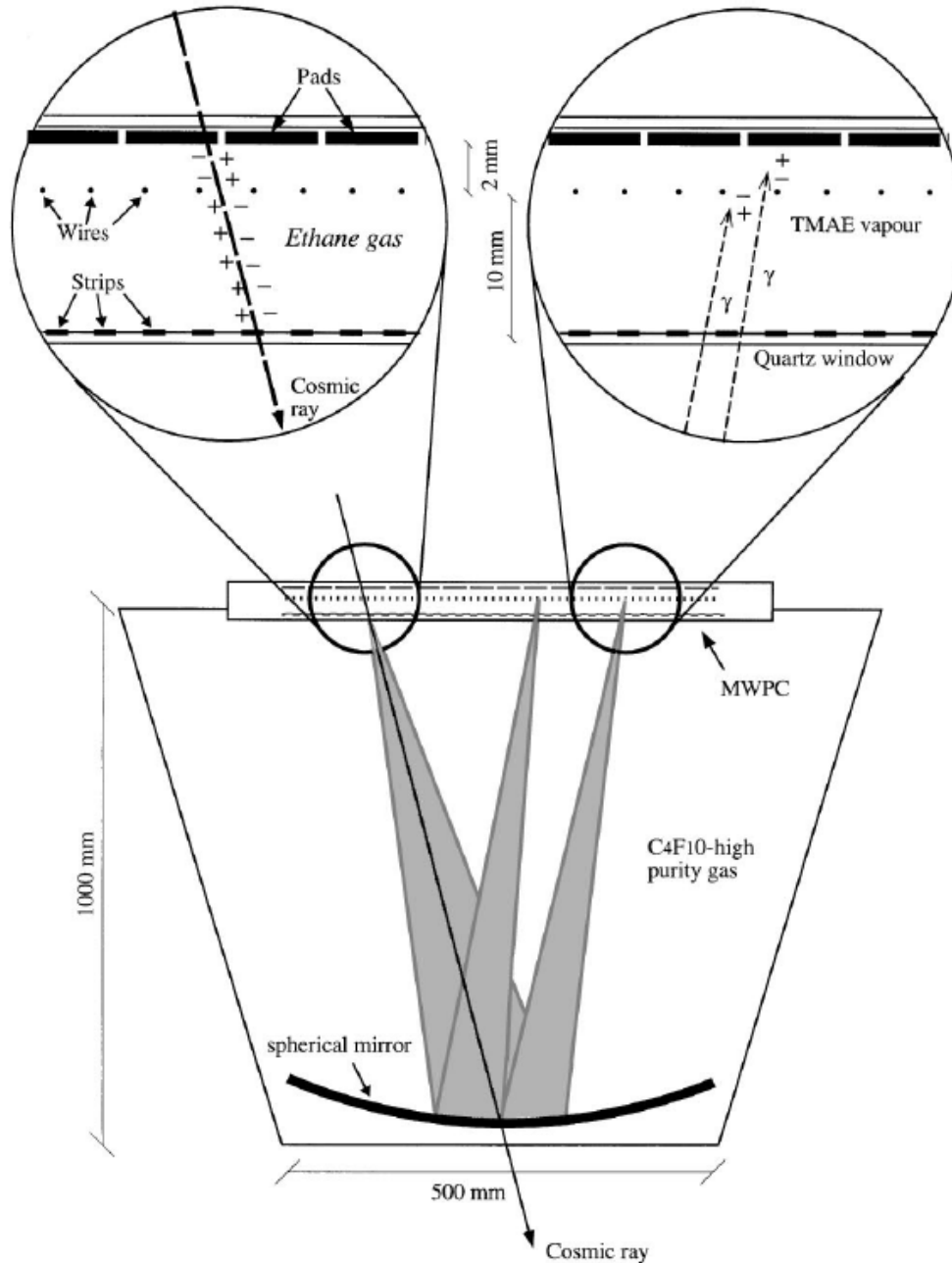

TMAE:
(tetrakis(dimethylamino)
ethylene)

Photodetector with CsI photocathode

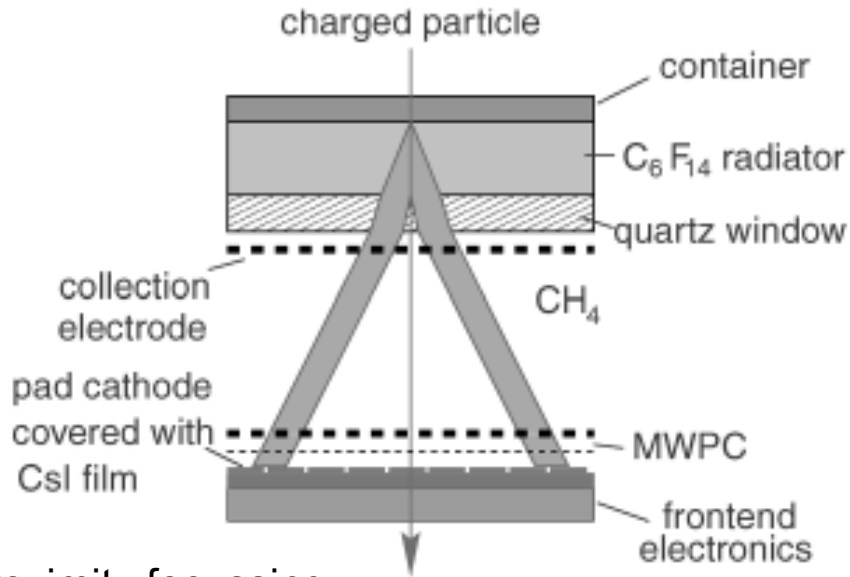

➤ Used in ALICE experiment at CERN

➤ Thickness of :

- radiator = 10mm
- quartz window= 5mm
- MWPC gaps= 2 mm
- Wire cathode pitch=2 mm
- Anode pitch= 4 mm
- anode diameter= 20 micron
- pad size = 8*8 mm²

➤ Total detector area: 12 m²

➤ Open geometry: using MWPC

Proximity focussing

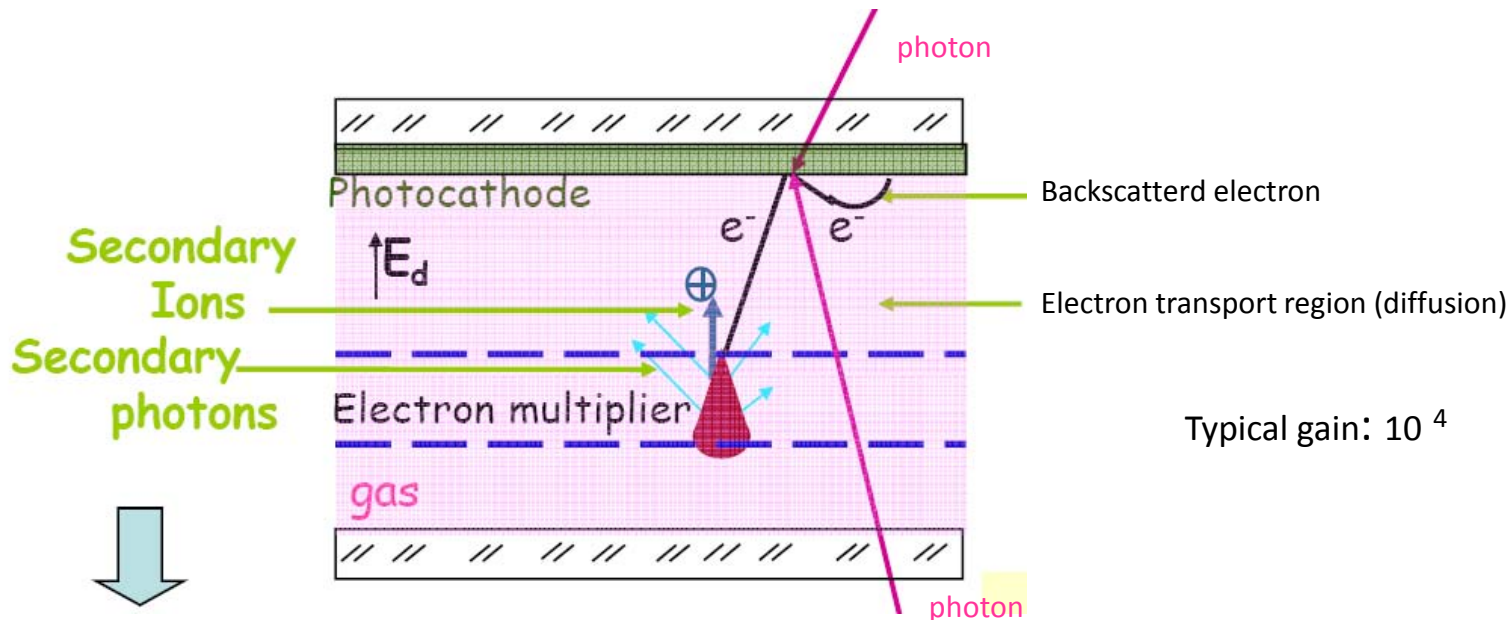

Typical gain: 10⁴

cause feedback: leading to loss of original signal info.

Recent Developments: Gas Based Photodetectors

GEM: Gas Electron Multiplier

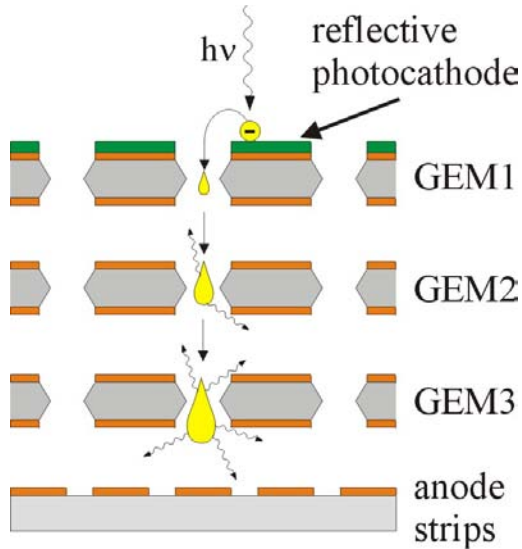

GEM with semi-transparent Photocathode (K-Cs-Sb)

- Photon and ion feed back reduced.
- Gated operation to reduce noise.
(no readout outside a 'time window of signal')
- For now only closed geometry (in sealed tubes):
Reduced fraction of useful area for photon detection (Active Area Fraction) compared to open geometry.

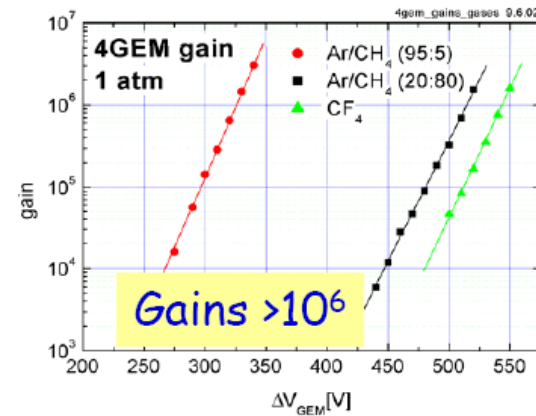

Vacuum Based Photodetectors

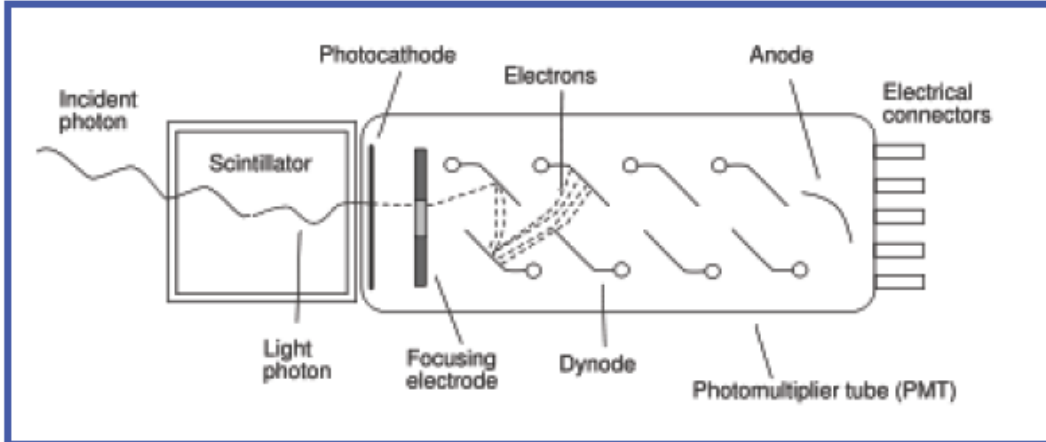

Schematic of a photomultiplier tube coupled to a [scintillator](#).



PMTs

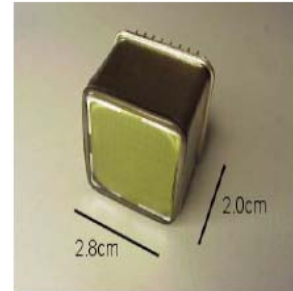

MAPMT

Schematic view of HPD

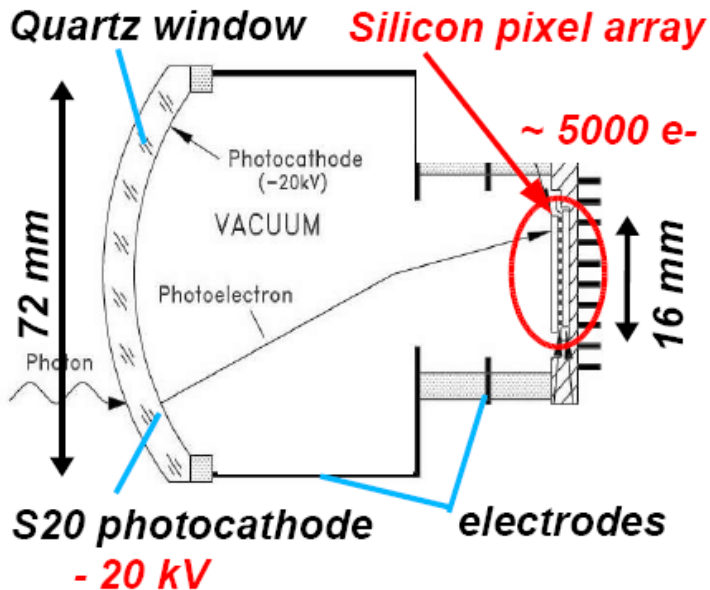

- PMTs Commercially produced: more info in www.sales.hamamatsu.com

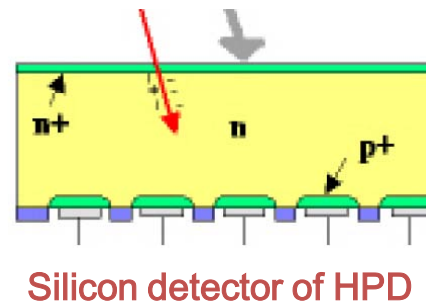

Silicon detector of HPD



HPD

Features of HPD

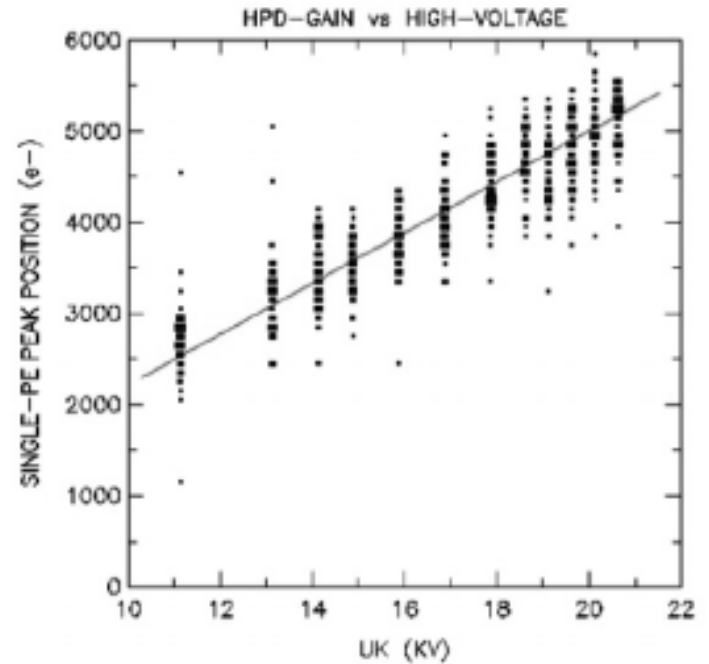
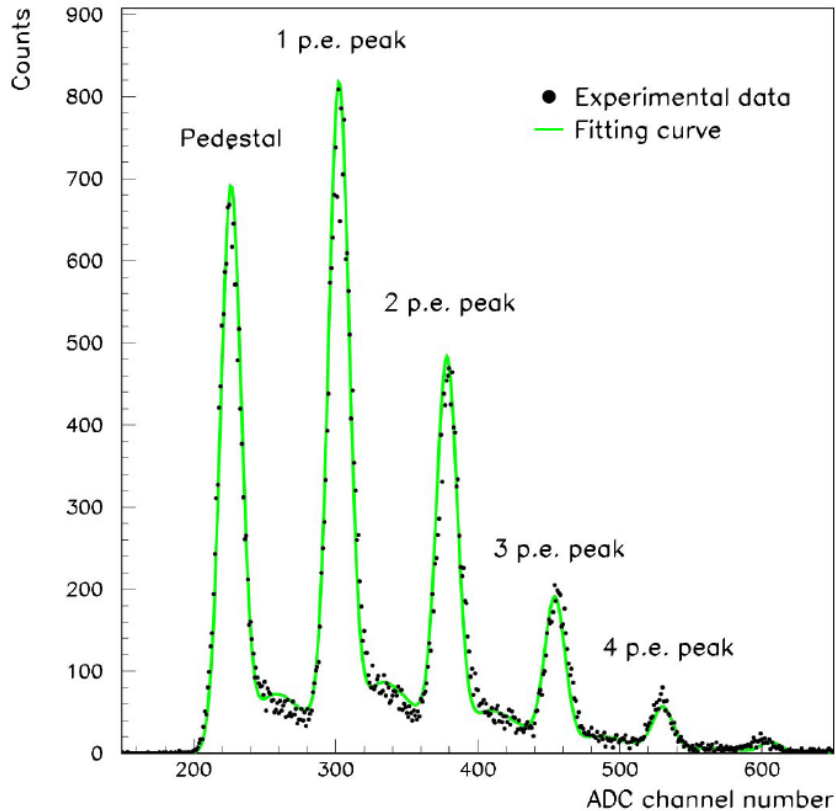

Signal pulse height spectrum of a 61-pixel HPD
Illuminated with Cherenkov photons

- Band gap in Silicon = 3.16eV; Typical Max Gain = 20 keV / 3.16 eV = 5000 (approx)

Features of the PMTs and HPDs

- PMT:
 - Typical Gain of MAPMT 300 K.
 - Excellent time resolution: 125 ps for example
(Ex: used in underwater Cherenkov detectors).
 - Active area fraction: 40 % : Fraction of effective detection area.
This can be Improved with a lens, but then one may loose some photons at the lens surface.
 - Recent developments: Flat panel pmts with 89 % active area fraction.
New photocathodes with >45% QE at 400 nm

- HPD:
 - Typical gain 5K, but quite uniform across different channels.
 - Excellent Single photon identification capability.
 - Active area fraction: 35→ 76 %

Comparison of photodetectors

- Choice of photodetector depends on the design of the Cherenkov detectors and constraints on cost etc.

- Gaseous:

- Issues:

- Related to photon and ion feed back and high gains at high rate.
 - Detection in visible wavelength range (for better resolution)

- Advantages:

- Can operate in high magnetic field
 - Lower cost for large size detectors compared to vacuum based

- Vacuum based:

- Issues:

- Sensitivity to magnetic field
 - cross talk between readout channels in case of MAPMTs
 - Active Area Fraction

- Advantages:

- Can easily operate at high rate (eg. LHC rates and higher).
 - Operates also in visible wavelengths.
 - Ease of operation at remote locations: underwater, in space etc.
 - HPD: uniform gain over large number of tubes and small noise.

- Other Types and new developments: **APD, Silicon photomultiplier, HAPD , MCP etc.**

Recent Developments: Silicon Photomultipliers

- Primary building block, GM-APD.

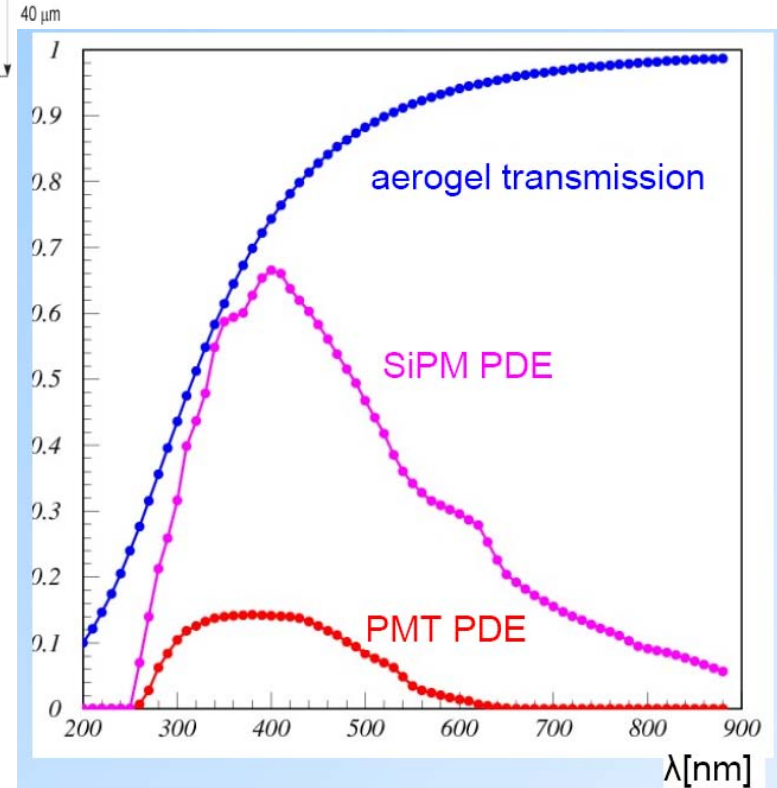
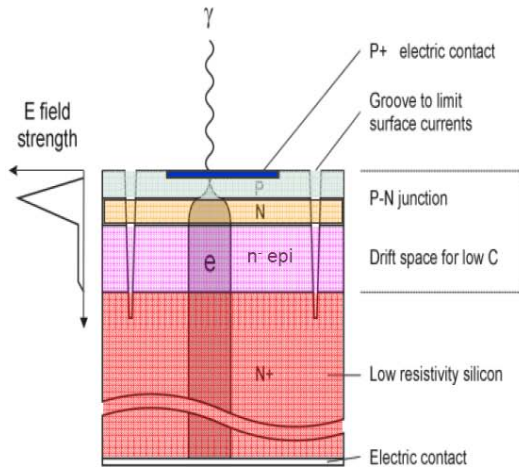
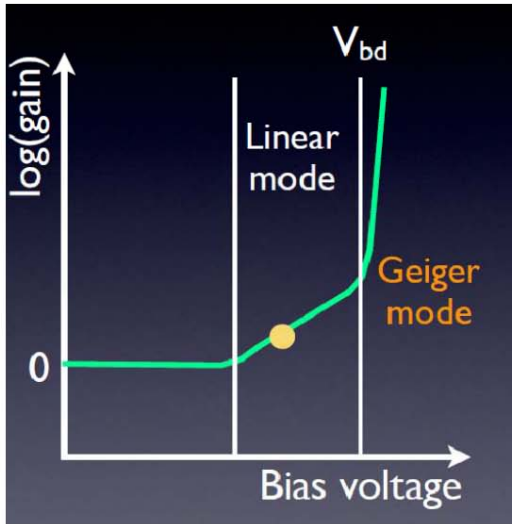

- Photon Detection Efficiency (PDE) for SiPM about 5 times that of ordinary PMT.
- Time resolution = ~ 100 ps.
- Works in magnetic field
- gain = $\sim 10^6$
- Reducing noise levels for single photon detection is still an issue and is being worked upon.

New Developments: Micro Channel Plate (MCP) Photon Detectors

Proximity focused MCP tube with 55um pixel readout

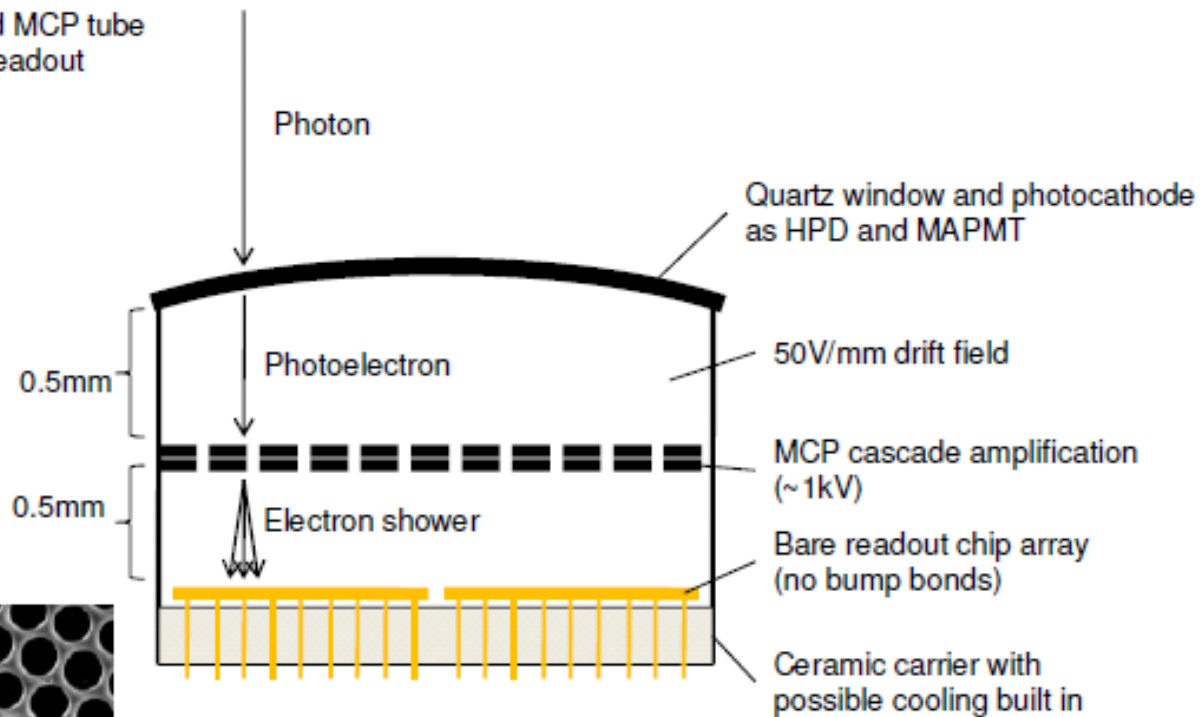

Tuning the lower drift field allows the electron shower profile to be well controlled

Cascade amplification similar in principle to a PMT

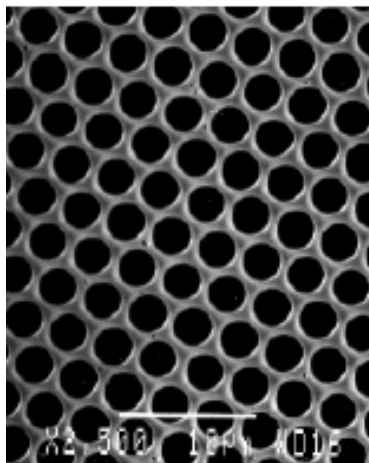

10um pores in an MCP

New Developments: Micro Channel Plates (MCP)

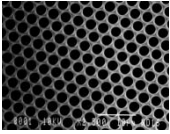

Typical Size:

- 2 mm thickness, 51 mm X 51 mm active area.
- 10 micron pores separated by 15 microns
- Chevron: 8 degree tilt : To increase the gain and reduce ion-feed back
- Gain: $\sim 5 * 10^5$
- Typically ~ 1000 channels per MCP.

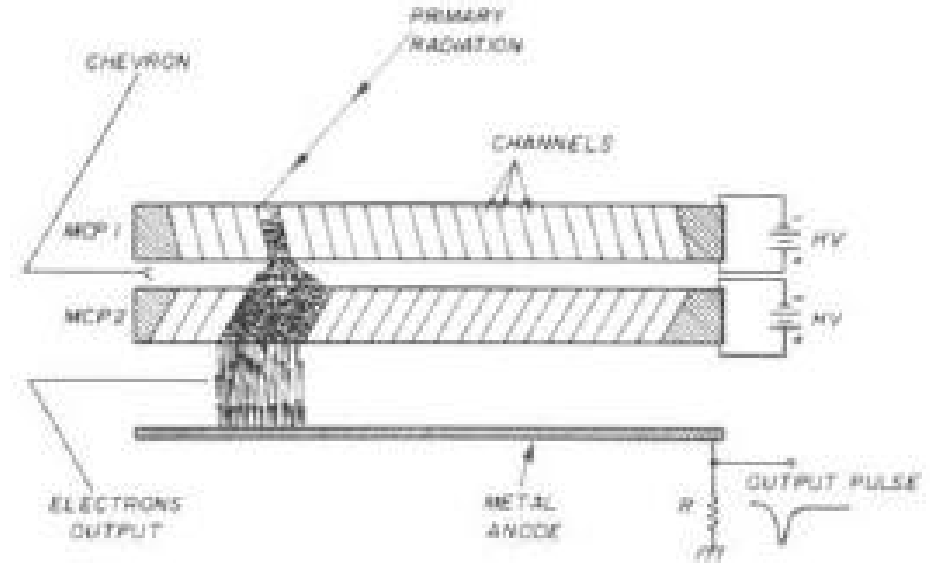

(SIDE VIEW)

- Measure Space and time of the hits.
- Manufactured by industry (Photonics for example).
- Resolutions: Space: ~ 100 microns, Time: $\sim 50 - 100$ psec.
- Short flight path of photoelectrons: Resistant to magnetic fields up to 0.8 Tesla.
- Can work at 40 MHz readout rate.
- Can detect single photons (No noise from 'first dynode' as in MAPMT).
- Fast 'ageing' at large luminosity (eg: LHC) is an issue, but there are some solutions.

LHCb Experiment

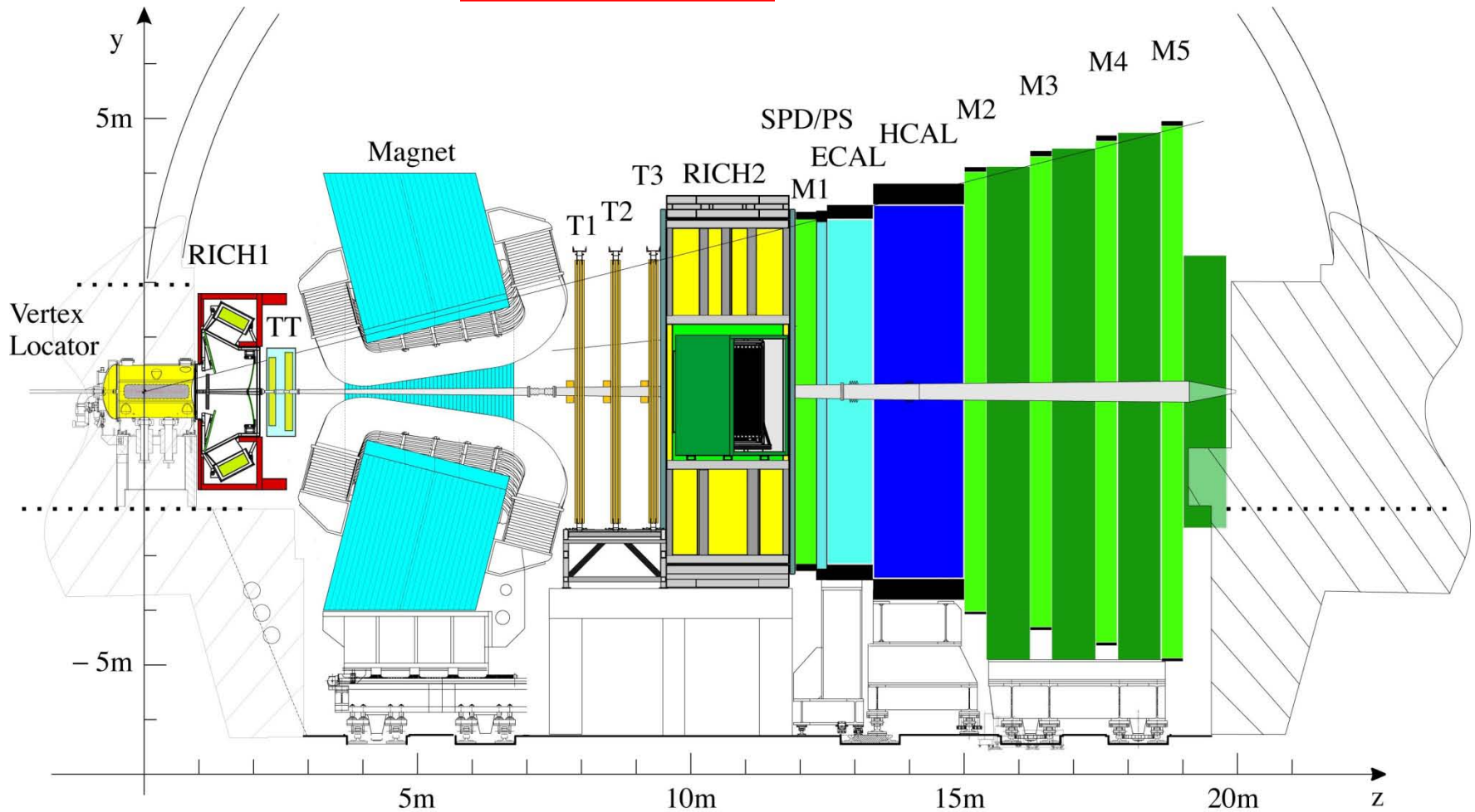

- Precision measurement of B-Decays and search for signals beyond standard model.
- Two RICH detectors covering the particle momentum range $1 \rightarrow 100$ GeV/c using aerogel, C_4F_{10} and CF_4 gas radiators.

LHCb-RICH Design

RICH1: Aerogel L=5cm p:2→10 GeV/c
n=1.03 (nominal at 540 nm)
C₄F₁₀ L=85 cm p: < 70 GeV/c
n=1.0014 (nominal at 400 nm)

Upstream of LHCb Magnet

Acceptance: 25→250 mrad (vertical)
300 mrad (horizontal)

Gas vessel: 2 X 3 X 1 m³

RICH2: CF₄ L=196 cm p: < 100 GeV/c
n =1.0005 (nominal at 400 nm)

Downstream of LHCb Magnet

Acceptance: 15→100 mrad (vertical)
120 mrad (horizontal)

Gas vessel : 100 m³

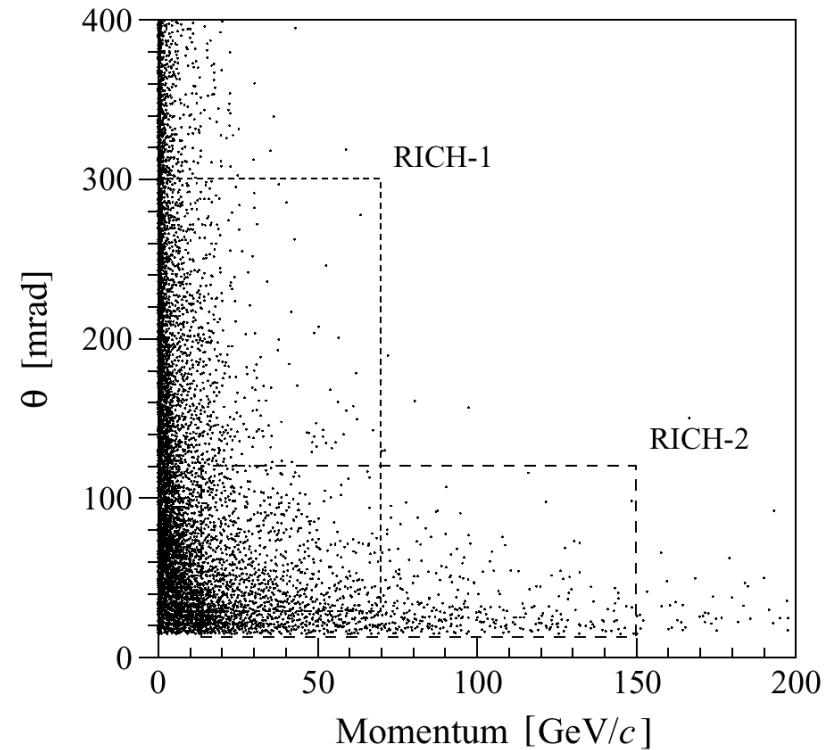

LHCb-RICH Specifications

RICH1: Aerogel $2 \rightarrow 10$ GeV/c
 C_4F_{10} < 70 GeV/c

RICH2: CF_4 < 100 GeV/c.

	Aerogel	C_4F_{10}	CF_4
L	5	86	196 cm

	Aerogel	C_4F_{10}	CF_4
θ_c^{\max}	242	53	32 mrad

	Aerogel	C_4F_{10}	CF_4
π_{Th}	0.6	2.6	4.4 GeV/c

	Aerogel	C_4F_{10}	CF_4
K_{Th}	2.0	9.3	15.6 GeV/c

Aerogel: Rayleigh Scattering

$$T = A e^{-Ct/\lambda^4}$$

Typically: $A = 0.94$, $C = 0.0059 \mu\text{m}^4/\text{cm}$

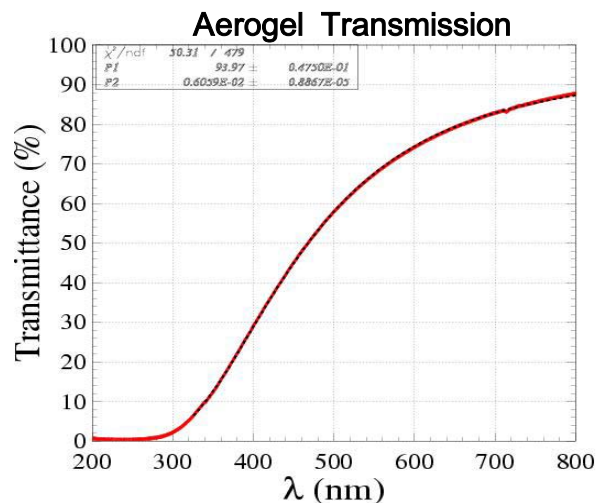
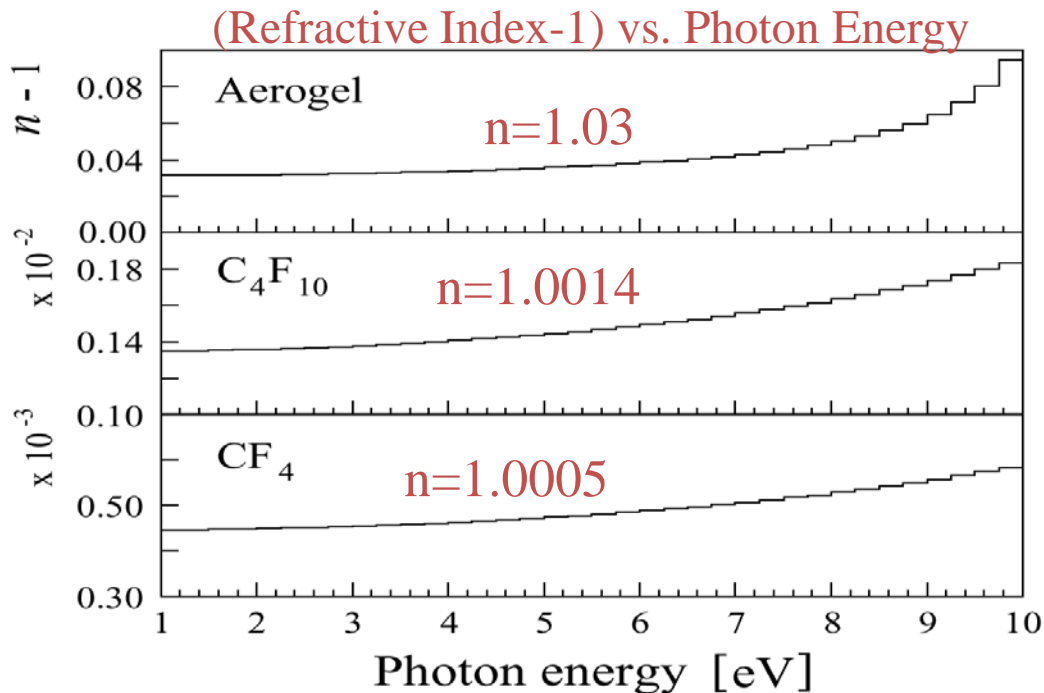

LHCb- RICH1 SCHEMATIC

RICH1 OPTICS

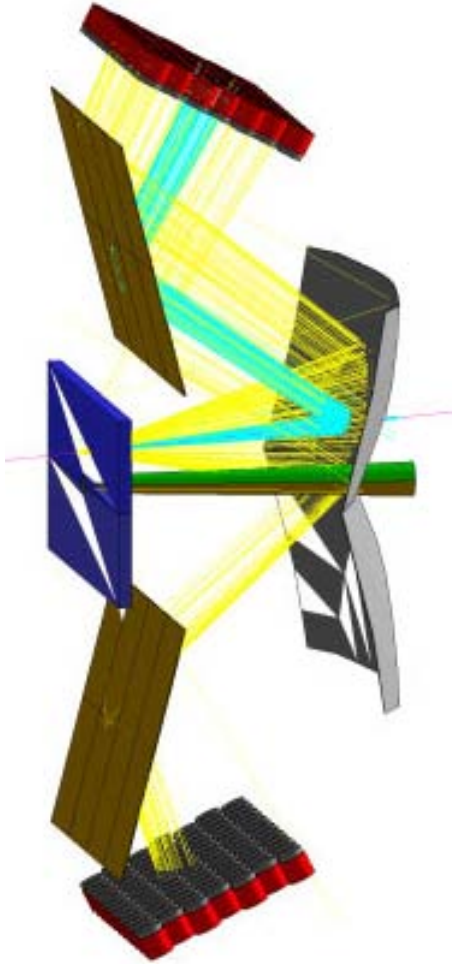

Magnetic Shield

Gas Enclosure

Beam Pipe

Spherical Mirror

Flat Mirror

Photodetectors

Readout Electronics

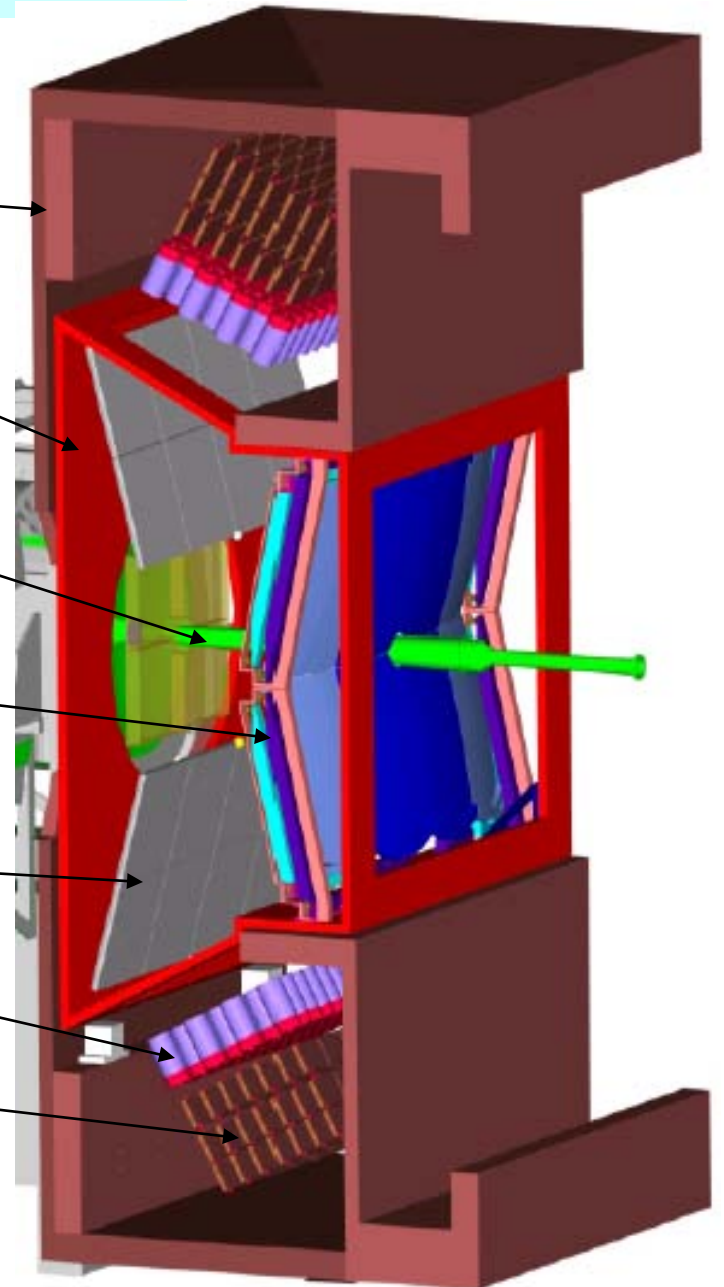

- Spherical Mirror tilted to keep photodetectors outside acceptance (tilt=0.3 rad)

RICH1 Photos



RICH1-HPDs



RICH1 mirrors

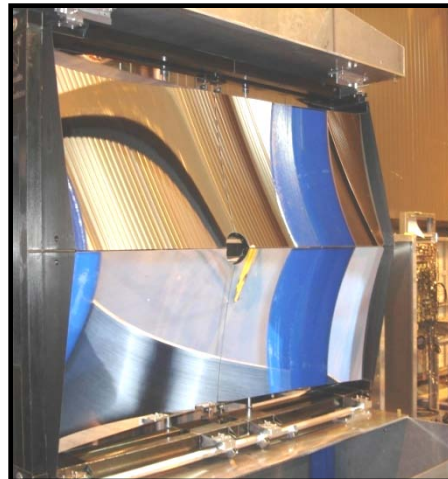

LHCb-RICH2 SCHEMATIC

RICH2 Optics Top View

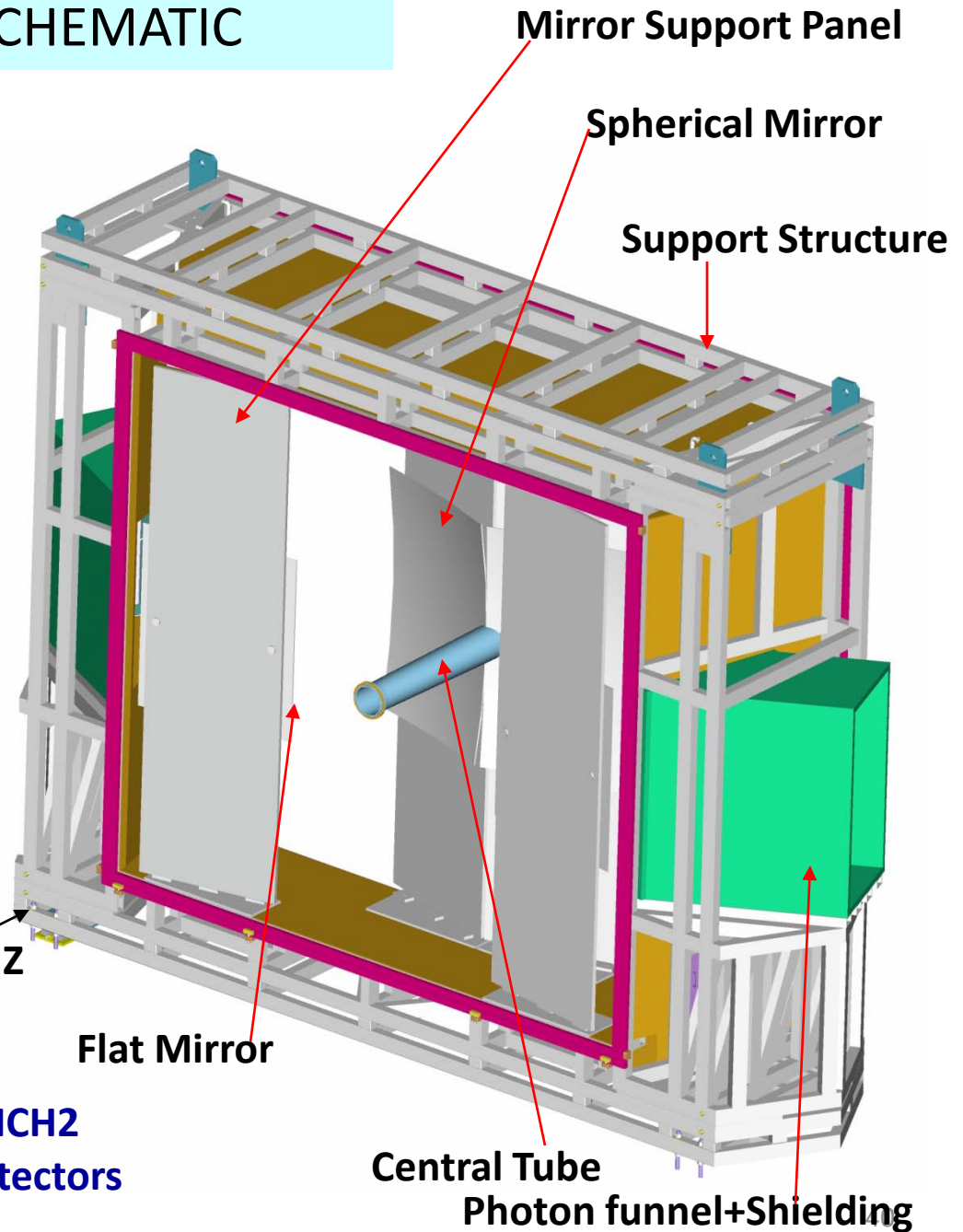
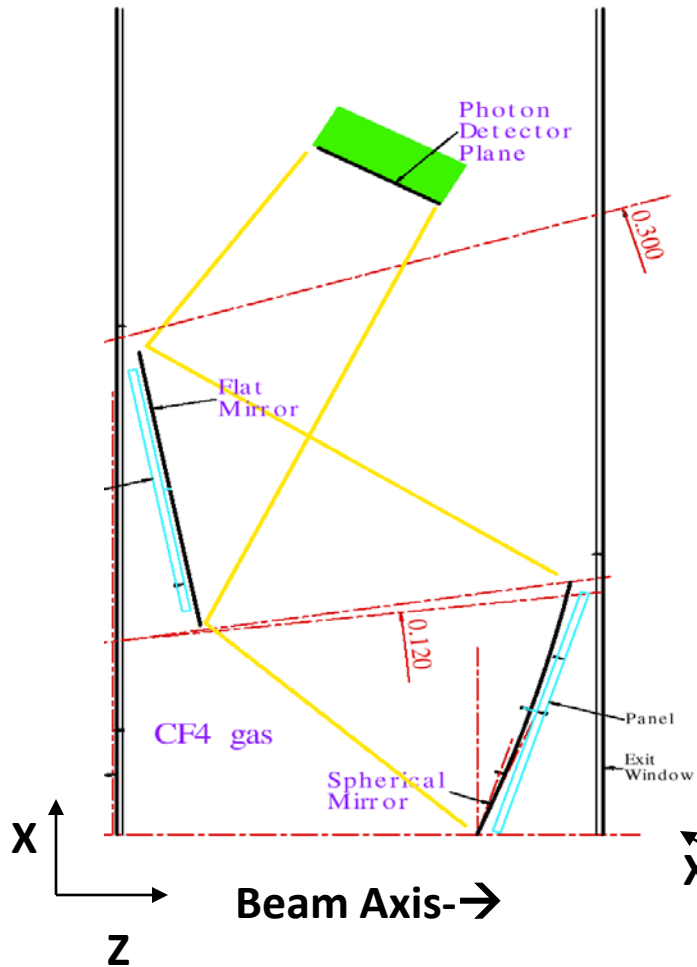

- Plane Mirrors to reduce the length of RICH2
- Spherical mirror tilted to keep photodetectors outside acceptance. (tilt=0.39 rad)

LHCb- RICH2 STRUCTURE

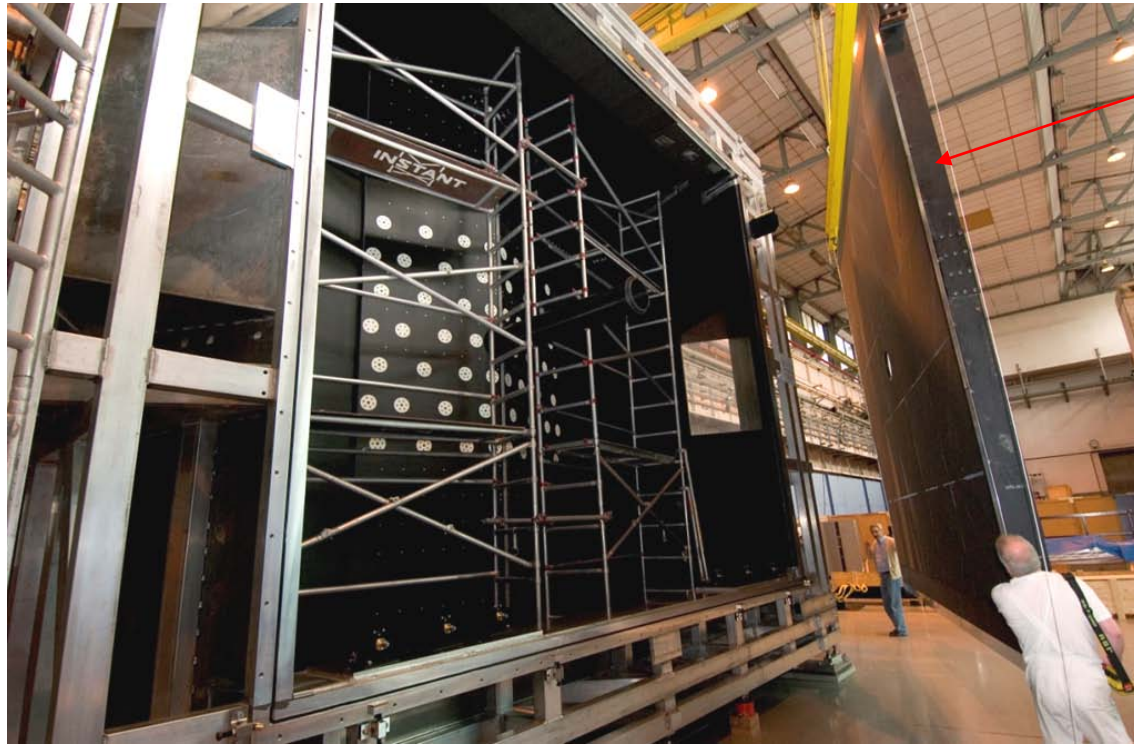

**Entrance Window
(PMI foam between two
carbon fibre epoxy Skins)**

RICH2



Typical Hits on LHCb-RICH HPDs

LHCb Preliminary data

HitMap for Rich1 top panel

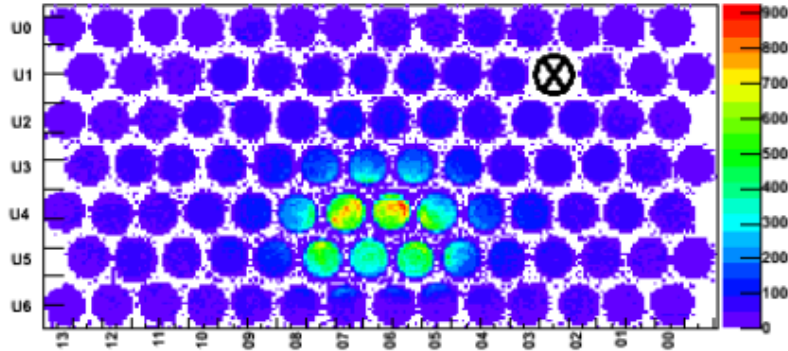

HitMap for Rich1 bottom panel

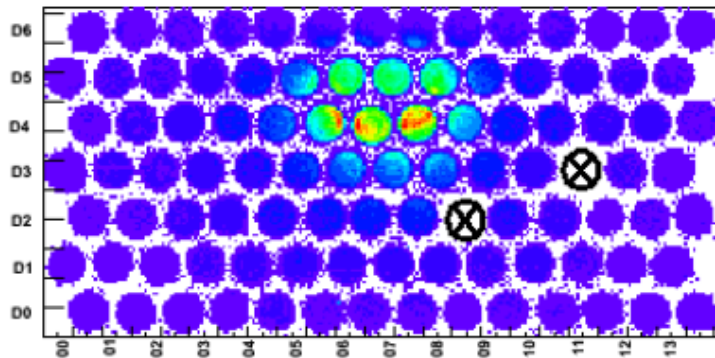

HitMap for Rich2 CSide-right panel

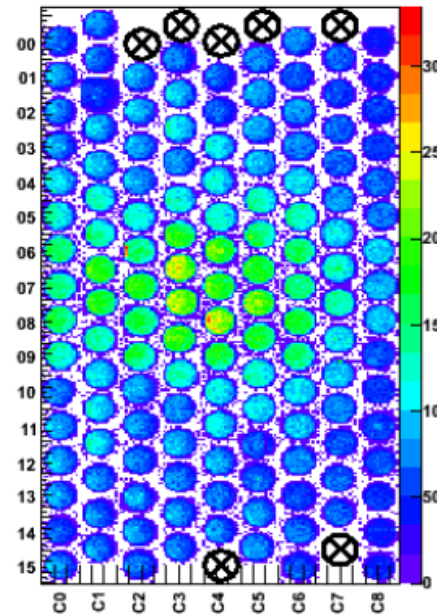

HitMap for Rich2 ASide-left panel

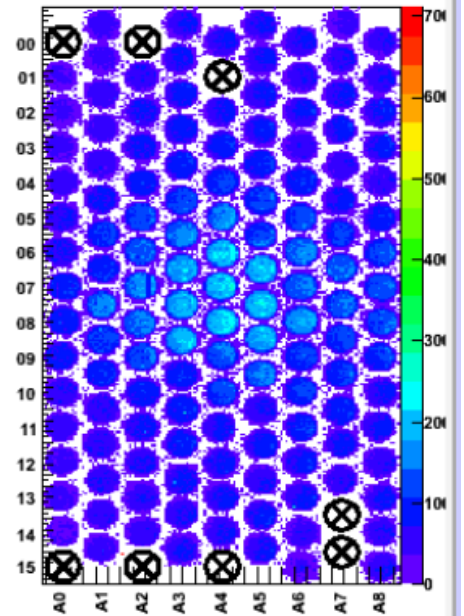

- In 2010 -11, LHCb-RICH continues to collect data
- These data were aligned in space and time with the rest of LHCb. The particle identification performance was calibrated.

LHCb-RICH Preliminary data

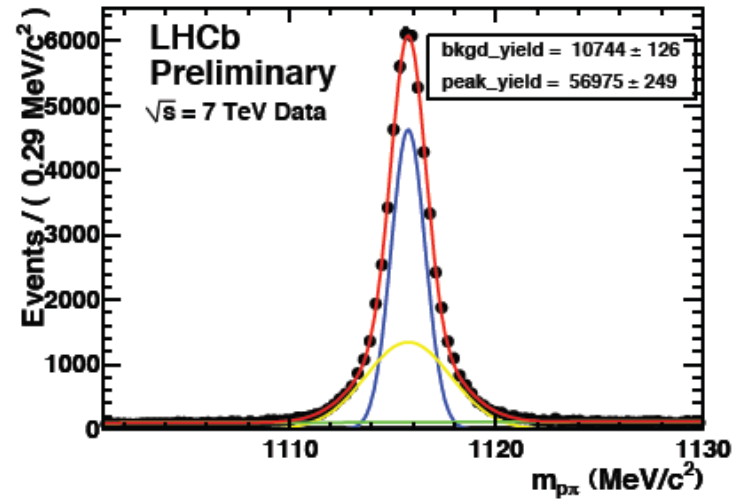
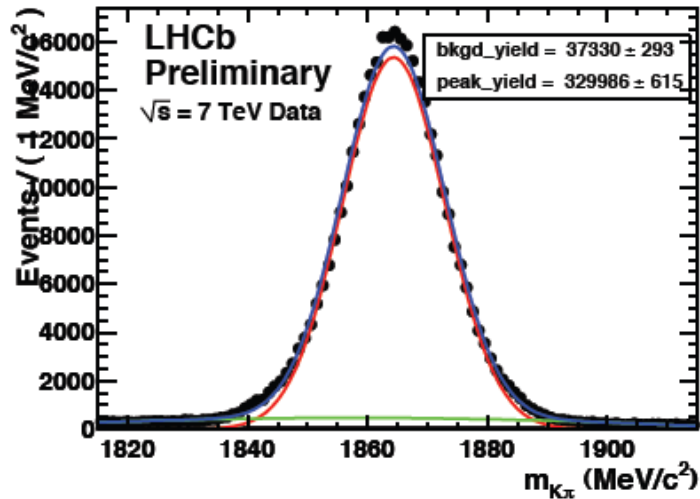
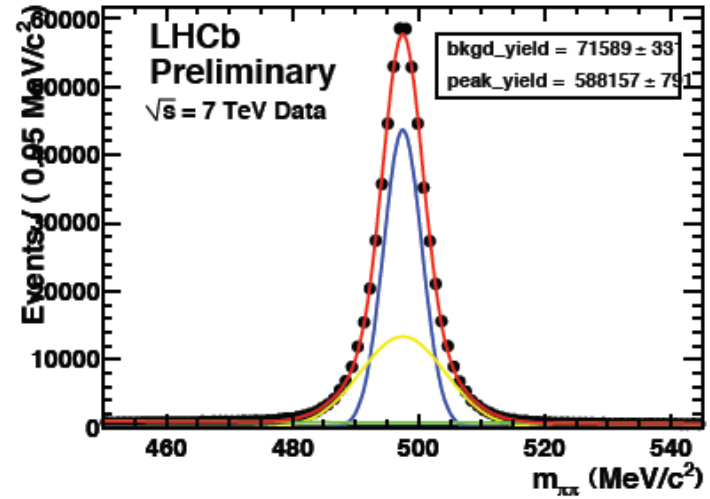
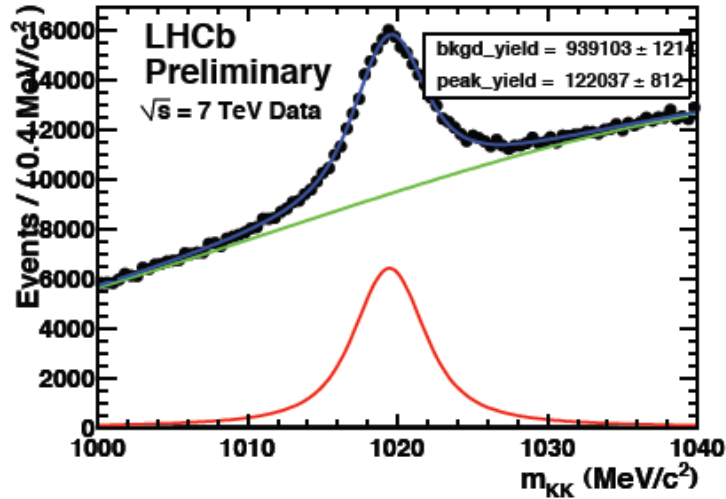

- Examples of signals for $\Phi \rightarrow KK$, $K_s \rightarrow \pi\pi$, $D \rightarrow K\pi$, $\Lambda \rightarrow p\pi$ obtained using RICH.
- The data from RICH used for Physics Analysis.

Example of LHCb-RICH PERFORMANCE

- Performance as seen in Simulated Data in 2006
- **Yield: Mean Number of hits per isolated saturated track (Beta ~1).**

Aerogel	C4F10	CF4
5.3	24.0	18.4

Single Photon Cherenkov Angle Resolutions in mrad.

Components and Overall (mrad)	Aerogel	C₄F₁₀	CF₄
Chromatic	2.36	0.90	0.46
Emission Point	0.38	0.82	0.36
Pixel Size	0.52	0.52	0.17
PSF	0.54	0.53	0.17
Overall RICH	2.53	1.44	0.66
Overall RICH+Tracks	2.60	1.60	0.70

- **Chromatic:** From the variation in refractive index.
- **Emission Point:** Essentially from the tilt of the mirrors.
- **Pixel Size:** From the granularity of the Silicon detector pixels in HPD
- **PSF (Point Spread Function):**
From the spread of the Photoelectron direction as it travels inside the HPD,
(from the cross focussing in the electron optics)

LHCb: Hits on the RICH from Simulation

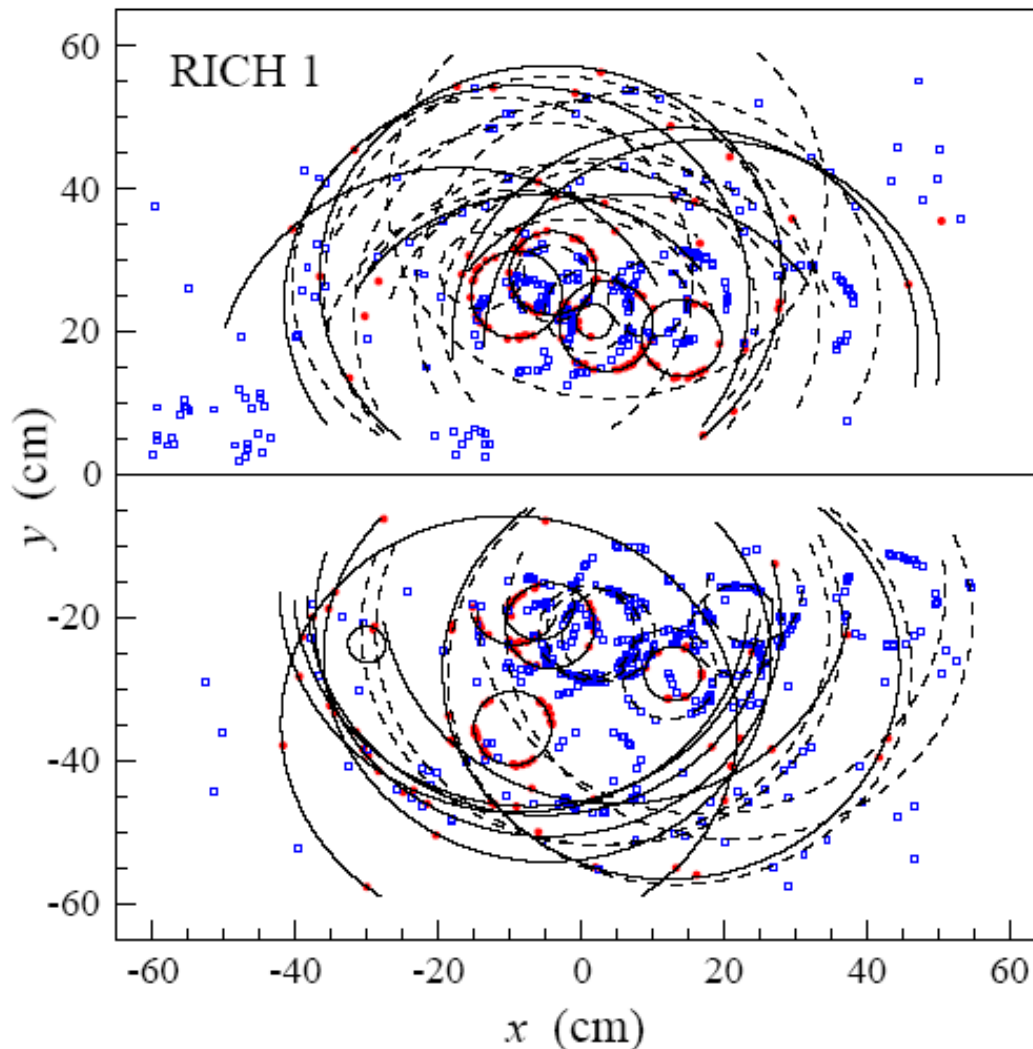

Red: From particles from Primary and Secondary Vertex

Blue: From secondaries and background processes (sometimes with no reconstructed track)

Pattern Recognition in Accelerator based Cherenkov Detector

- Events with large number of charged tracks giving rise to several overlapping Cherenkov Rings on the Photo detector plane.
Problem: To identify which tracks correspond to which hits and then identify the type (e, π , p etc.) of the particle which created the tracks.
- Hough Transform:
(used by ALICE at CERN)
 - Project the particle direction on to the detector plane
 - Accumulate the distance of each hit from these projection points in case of circular rings.
 - Collect the peaks in the accumulated set and associate the corresponding hits to the tracks.
- Likelihood Method:
(used by LHCb at CERN)
 - For each of the track in the event, for a given mass hypothesis, create photons and project them to the detector plane using the knowledge of the geometry of the detector and its optical properties. Repeat this for all the other tracks.
 - From this calculate the probability that a signal would be seen in each pixel of the detector from all tracks.
 - Compare this with the observed set of photoelectron signal on the pixels, by creating a likelihood.
 - Repeat all the above after changing the set of mass hypothesis of the tracks. Find the set of mass hypothesis, which maximize the likelihood.

LHCb-RICH pattern recognition

Efficiency for identification
and probability for misidentification
vs Particle momentum

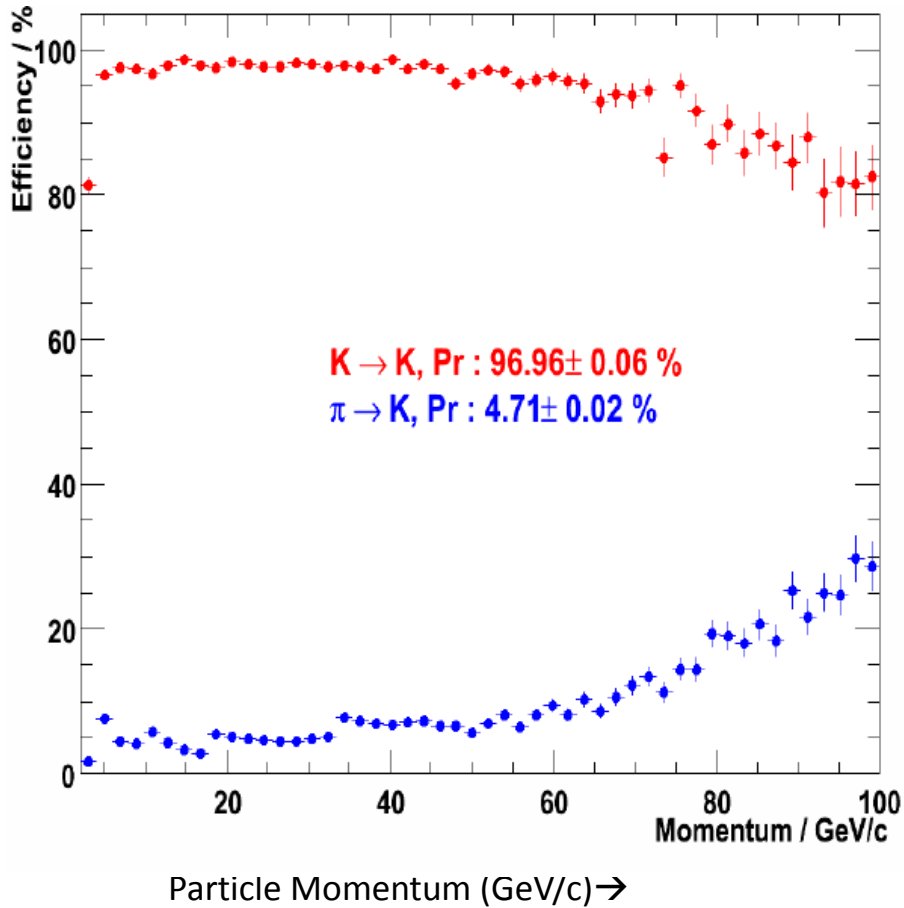

From simulations

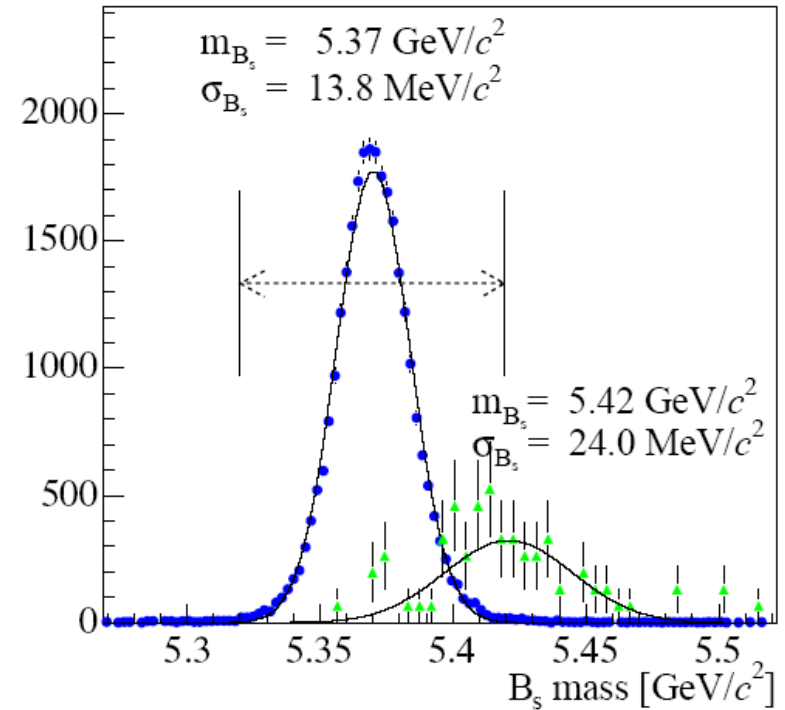

$B_s^0 \rightarrow D_s^- K^+$ $B_s^0 \rightarrow D_s^- \pi^+$

(signal)

(background)

After using RICH, background at 10%
level from 10 times level

dE/dx detectors: Silicon based

Bethe-Block formula (for $2\gamma m/M \ll 1$)

Energy loss by ionization

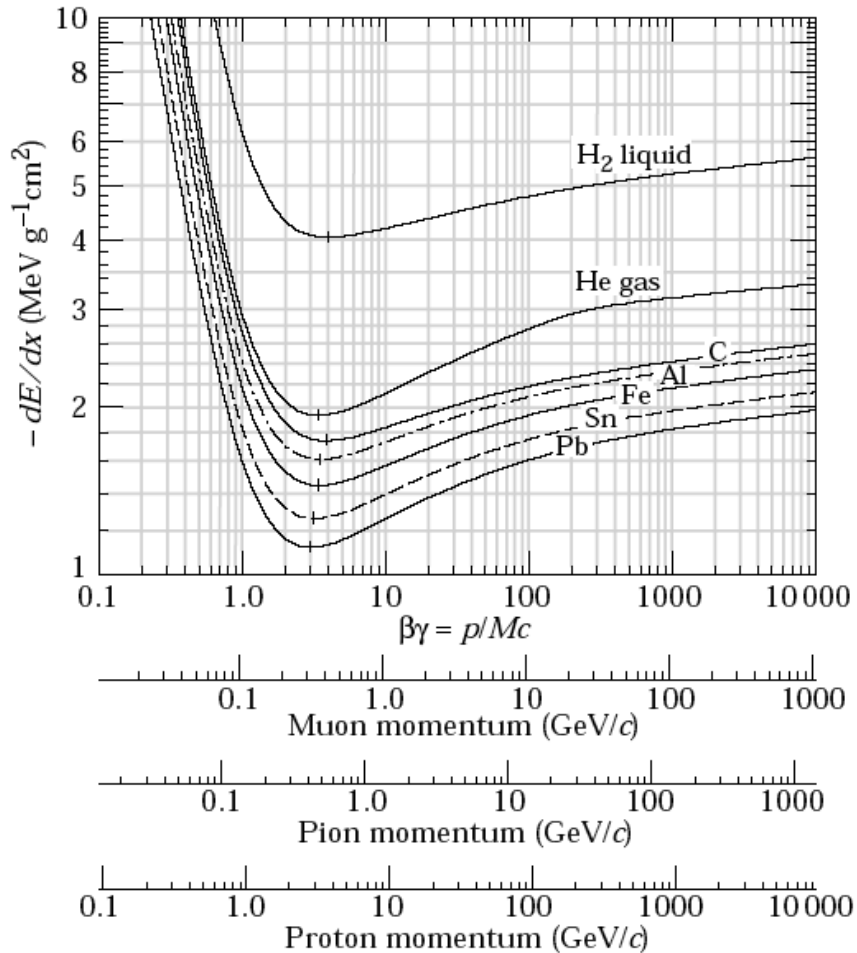

$$\frac{dE}{dx} = \frac{4\pi N e^4}{m c^2 \beta^2 z^2} \left(\ln \frac{2 m c^2 \beta^2 \gamma^2}{I} - \beta^2 \right)$$

For $0.2 < \beta < 0.9$, $dE/dx \sim (M/p)^2$

M, p = mass, momentum of the traversing particle

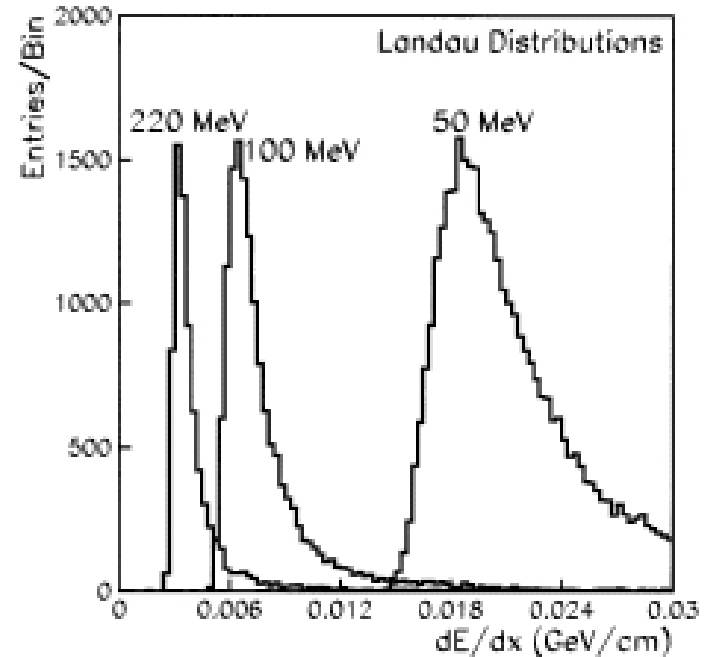

Fig. 1. Landau $\langle dE/dx \rangle$ distributions for pions of momenta 220, 100 and 50 MeV going through 300 μ m of silicon.

Ref: NIMA 469(2001) 311-315

FWHM= 30-35 %

dE/dx Detectors : Silicon based

- Each Silicon sensor gives a dE/dx measurement.
- Estimate the Most Probable Value from several (10-25) measurements (Truncated Mean: Ignore upper 40%)

CMS Silicon tracker:

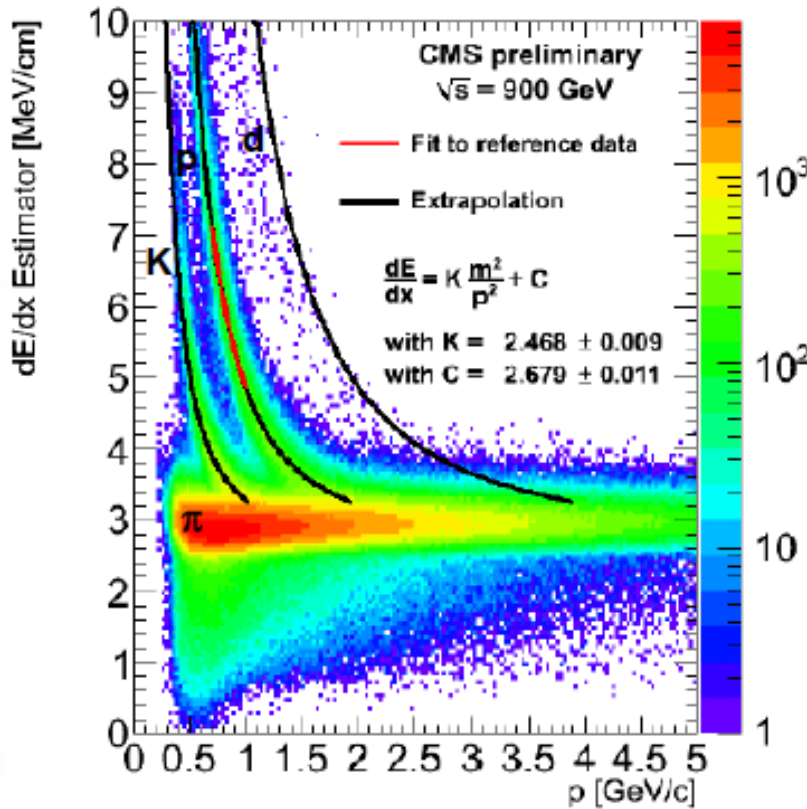

Data

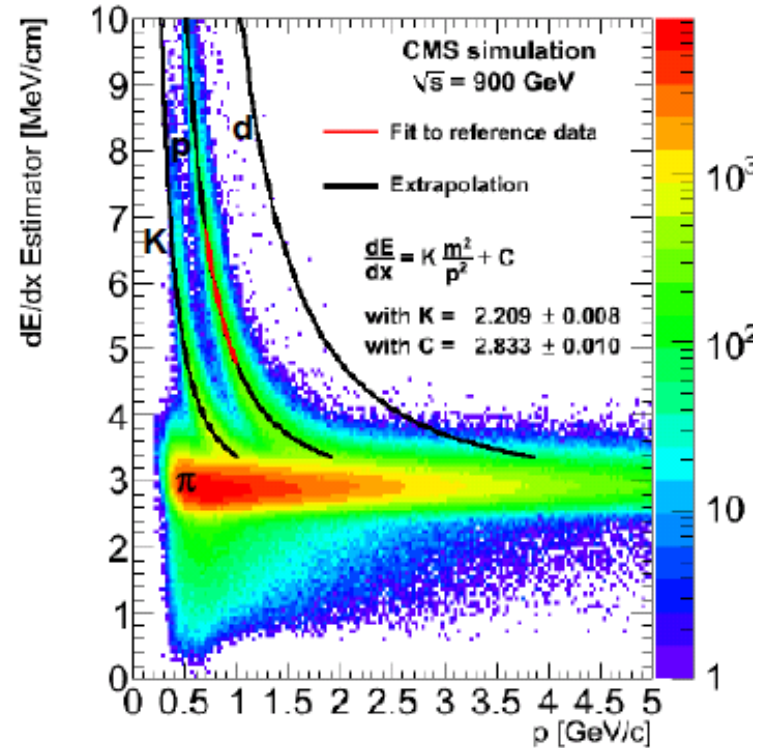

MC

CMS Silicon strip wafer

dE/dx Detectors: Drift Chambers

$$\frac{dE}{dx} = -0.3071 \frac{Z}{A} \rho t \frac{z^2}{\beta^2} \left[\frac{1}{2} \ln \frac{2m_e c^2 \beta^2 \gamma^2 E_{cut}}{I^2} - \frac{\beta^2}{2} - \frac{\delta}{2} \right]$$

Larger Landau fluctuations compared to those from Silicon detectors.
 So many measurements needed to get the average.

BABAR Drift Chamber:

Gas mixture 80% helium, 20% isobutane,
 3500–4000 ppm water vapor, ~ 80 ppm O_2

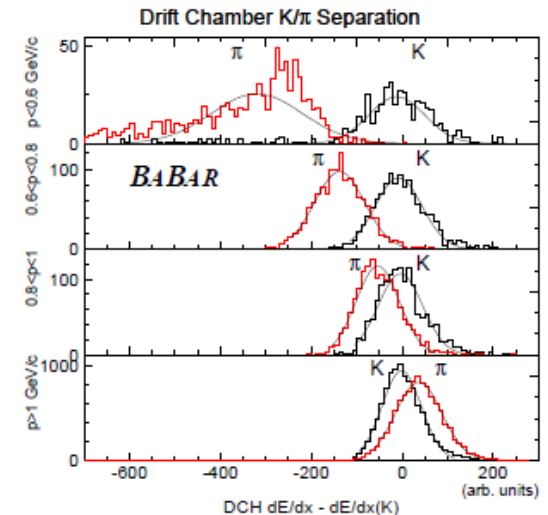
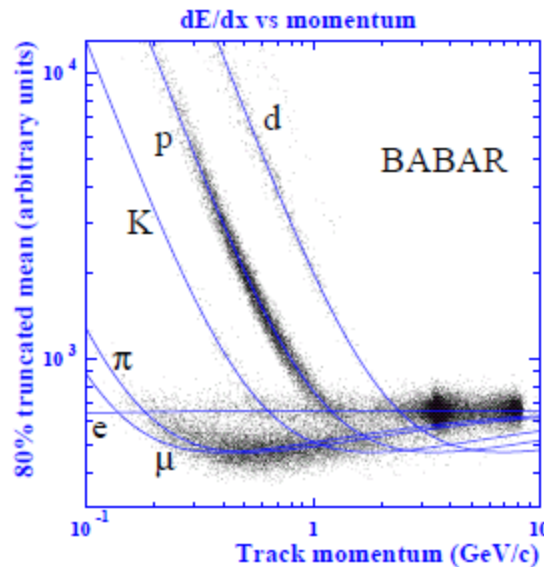
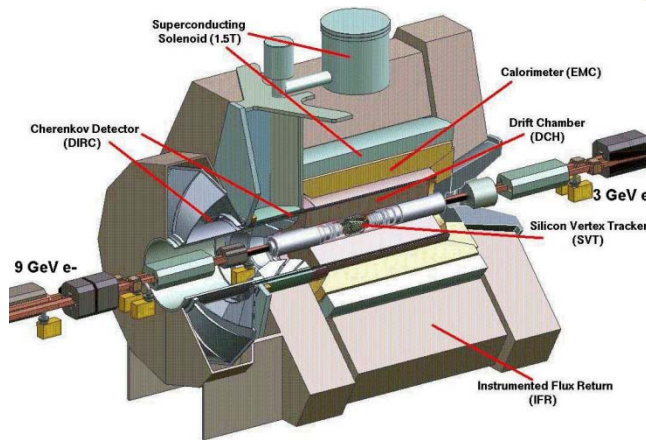

Good π/K separation up to ~ 700 MeV/c

Ref: IEEE-TNS VOL:47 , NO:6, Dec2000.

dE/dx resolution $\sim 7.5\%$

Time of Flight (TOF) Detectors

- For a charged particle traversing a detector:

using $L = v t$, $\beta = v/c = p/E = p / (p^2 + m^2)^{0.5}$

$$m = p \left((c t/L)^2 - 1 \right)^{0.5}$$

m =mass, p =Momentum, t =time,
 L = distance travelled,
 c =speed of light in vacuum.

Typically, the mass resolution here is dominated by the time resolution ,
 for example when $dp/p=1\%$ and $dL/L=0.001$.

For two particles, for $p \gg m$,

$$c \Delta t = L (m_1^2 - m_2^2) / (2 p^2)$$

At very high momentum, Δt will be too small and
 become comparable to detector resolution; so particle misID shall occur.

$$n = \text{separation in standard deviations} = L(m_1^2 - m_2^2) / (2 p^2 c \Delta t)$$

Typical values: $L = 3.5 \text{ m}$, $\Delta t = 100 \text{ ps}$, for 3σ separation, $P_{\text{max}} = 2.1 \text{ GeV}/c$

Time of Flight (TOF) Detectors

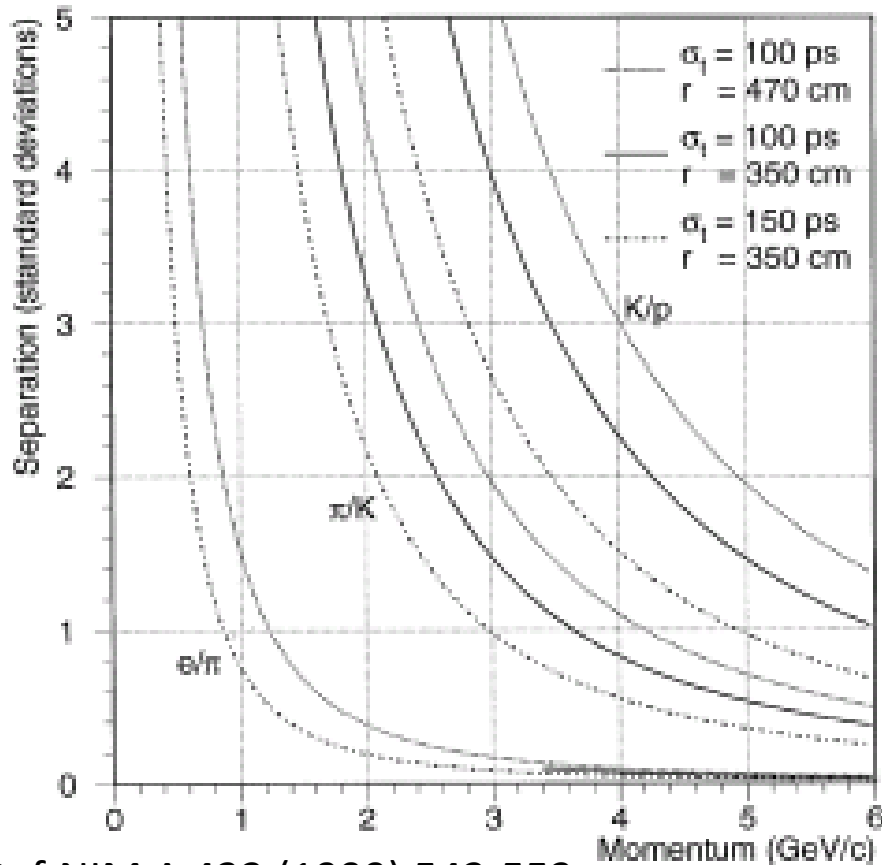

Ref: NIM A 433 (1999) 542-553

- New detectors reach somewhat higher momentum limit.

Example: LHCb upgrade proposal has a detector at $L=10$ m with $\Delta t=15$ ps, reaching up to 10 GeV/c for 3σ π -K separation.

Time of Flight (TOF) Detectors

Measurement of time: Using scintillators

Energy loss (dE/dx) from the charged particle = 2MeV/cm

This energy is re-emitted as optical photons in UV. (Approx 1 photon/100 eV)

Too small attenuation length and low yield.

Fluorescent material added to scintillator so that the photon re-emitted at longer wavelengths (ex: 400 nm) longer attenuation length (ex: 1 meter) and high yield . These photons collected by a PMT. (0.002 pe per emitted photon)

NA 49: Heavy ion expt, Scintillator thickness=2.3 cm, time resolutions= 59ps, 95 ps
Had a TPC to measure dE/dx .

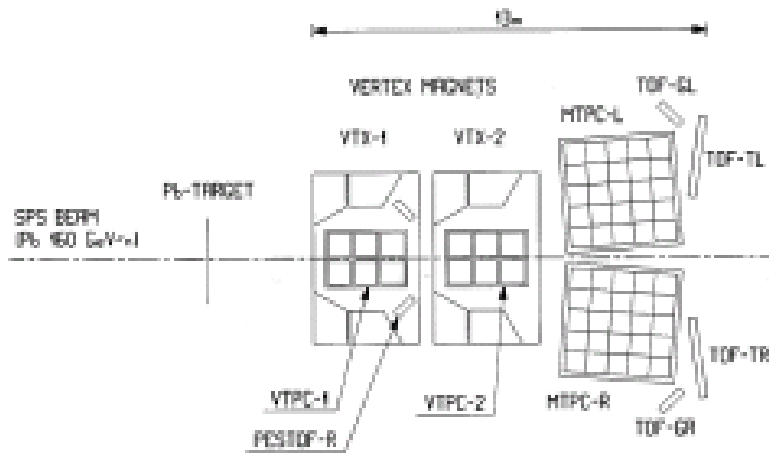
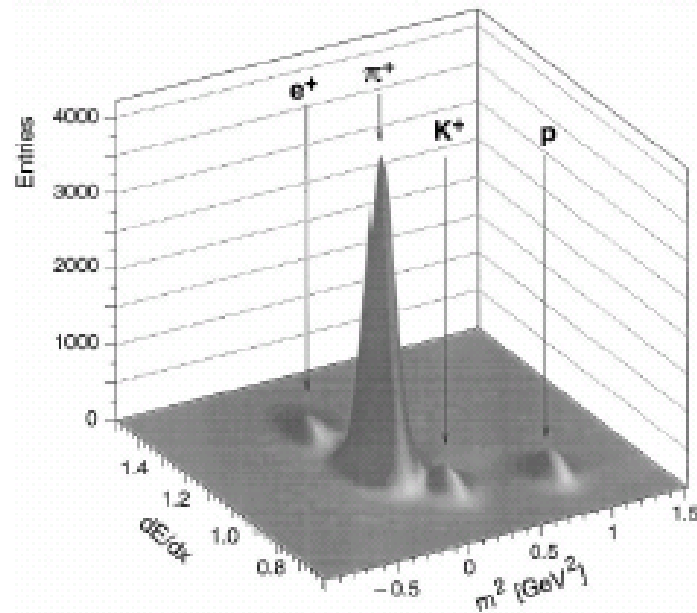

Fig. 2. Central part of the NA49 experimental setup.



Too expensive for large areas.

Time of Flight (TOF) Detectors

ALICE at CERN: using MRPC
(Multigap Resistive Plate Chamber)
Gas detector

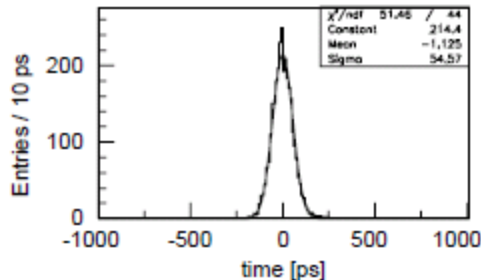
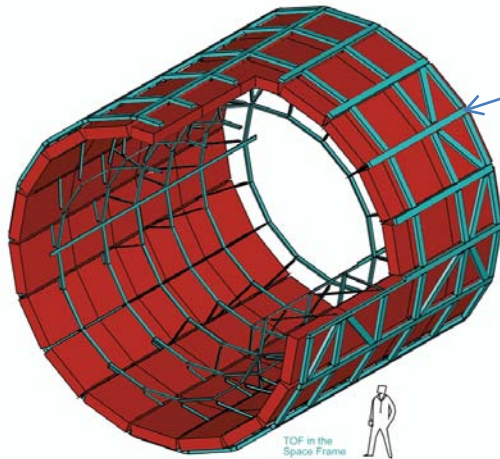
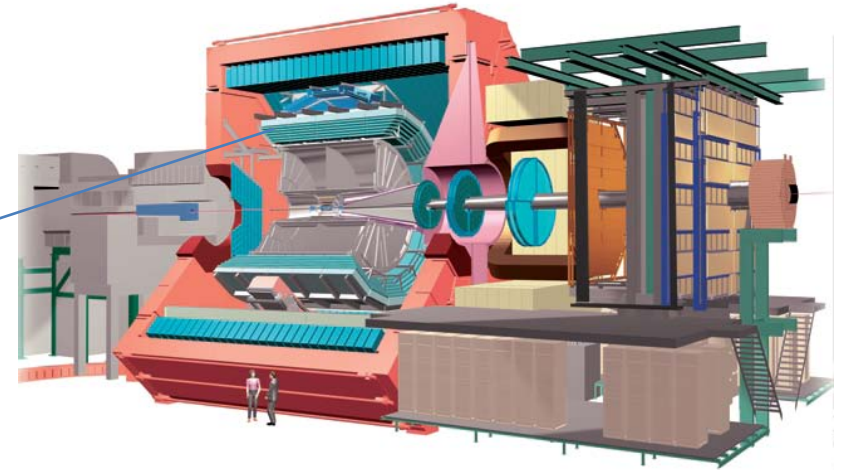

Performance in testbeam

Time resolution = 50 ps

PID in 0.5- \rightarrow 2.5 GeV/c

Cross-section of double-stack MRPC

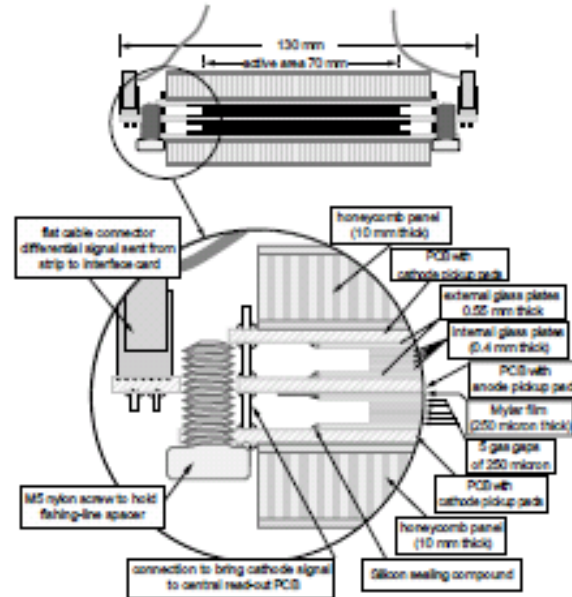

Fig. 1. Cross-section of the MRPC strip for the TOF system of ALICE.

Resistive plates
made of glass.
2 X5 gaps : 250 μ m
The resistive plates
stop the avalanche
development.

Use HPTDC
(High Performance
TDC)

Transition Radiation Detectors (TRD)

- Transition Radiation: Radiation in the x-ray region when ultra relativistic particles cross the boundary between 2 media with different dielectric constants.
- Mainly for $e-\pi$ separation in $0.5 \text{ GeV}/c \rightarrow 200 \text{ GeV}/c$.

Full explanations and the derivations from Maxwell's equations:

NIMA 326 (1993) 434-469 and references there in.

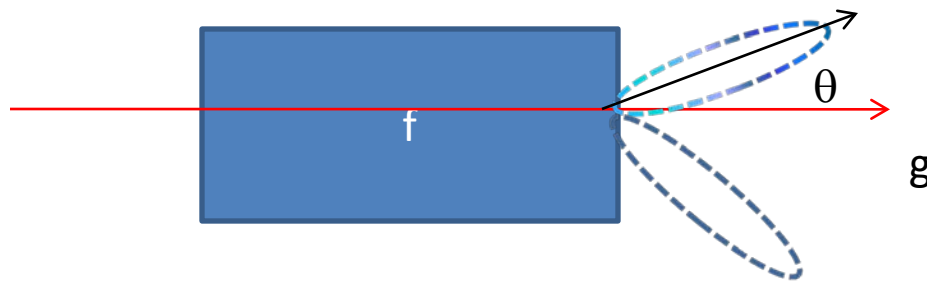

➤ The radiation is peaked at a small angle $\theta = 1/\gamma$.

The intensity of the radiation (after some approximations) becomes

$$\frac{dW}{d\omega d\theta} = \frac{2\alpha}{\pi} f_0(\theta) \quad \text{where} \quad f_0(\theta) = \theta^3 \left(\frac{1}{\gamma^{-2} + \theta^2 + \xi_e^2} - \frac{1}{\gamma^{-2} + \theta^2 + \xi_i^2} \right)^2$$

$\xi_i = \omega_i/\omega$, $\omega_i = \text{plasma freq of medium } i$

Transition Radiation Detectors (TRD)

Integration the previous equation, one can get , for $\xi_g = 0$,

$$W_{TR} = 2.43 \times 10^{-3} \omega_f \gamma$$

Here $\gamma = E/m$ of the particle. This makes PID possible by measuring W .
Lighter particle give larger signal

$$\omega_f = \text{plasma frequency} = 28.8 (\rho Z/A)^{0.5} \text{ eV}$$

ρ =density, Z =atomic weight,
 A =atomic number

For example, for $\omega_f = 0.02 \text{ keV}$ and $\gamma = 5000$, most of the photon energy is in the range $10 \text{ keV} < \omega < 100 \text{ keV}$ (ie. $0.1 \omega_c < \omega < \omega_c$ where $\omega_c = \text{cut-off frequency}$).

Number of photons produced=
$$N(> \omega) = \frac{\alpha}{\pi} \left\{ \ln \frac{\omega_c}{\omega} \left(\ln \frac{\omega_c}{\omega} - 2 \right) + \frac{\pi^2}{12} + 1 \right\}.$$

For $\omega_c = 100 \text{ keV}$ and $\omega = 1 \text{ keV}$, $N = 0.03$ for a single surface.

Hence to get sufficient number of photons , large number of interfaces are used : a stack of many foils with gaps in between.

Transition Radiation Detectors (TRD)

- The minimum thickness of the foils and air gaps are determined by the size of the 'formation zone' and the interference effects.
(typically foils can be 10-20 μm thick and are made of polypropelene)
- Behind a TRD foil stack there is a MWPC or drift chamber where the TRD signal is detected along with the signal from the charged track.

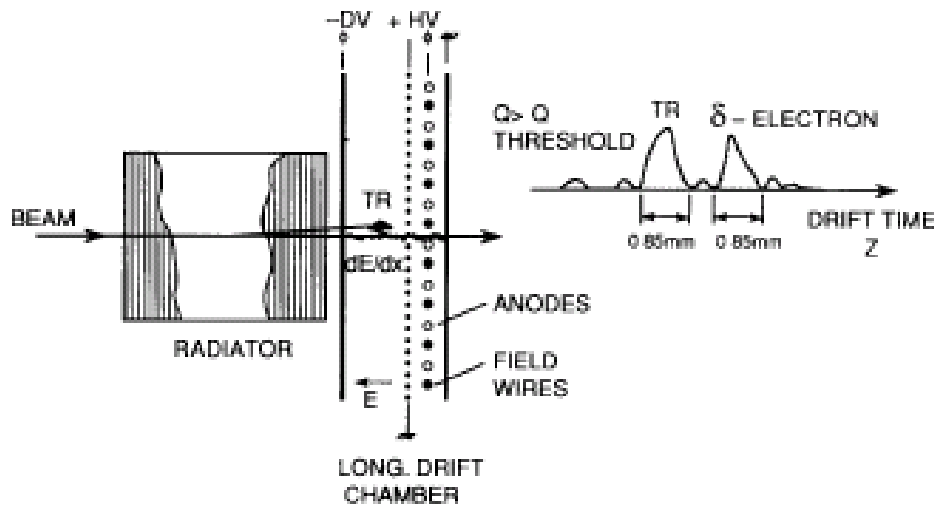

Drift space=10 mm,
Anode space=6 mm
Drift time=0.5 \rightarrow 1 μs
May use FADC
or discriminators

Example: HELIOS experiment (NA34)

Transition Radiation Detectors (TRD)

ATLAS Transition Radiation Tracker

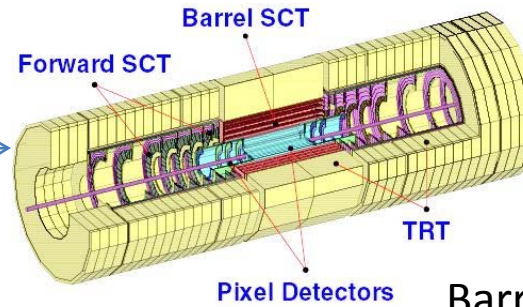
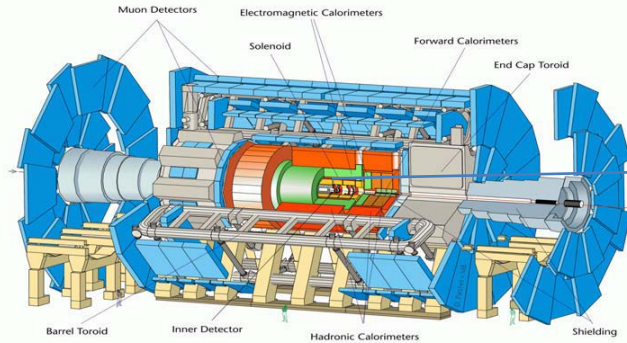

Barrel and endcap TRT

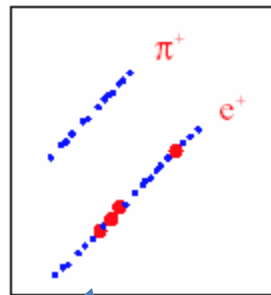
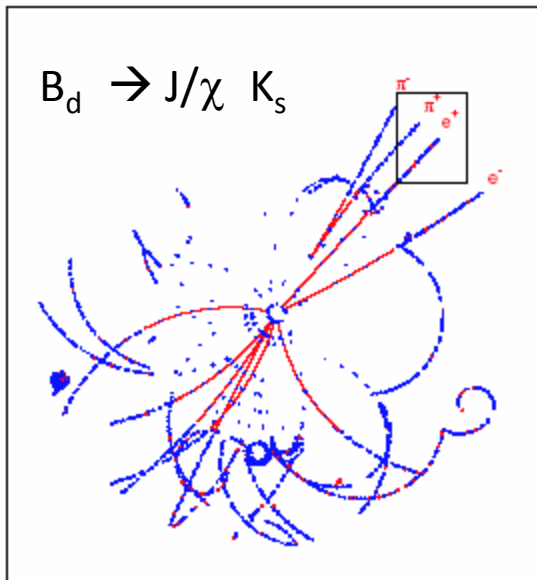
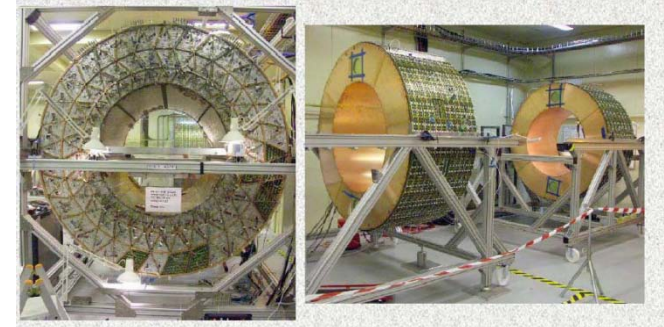

Blue dots: ionizing hits
Red dots : TR hits

*In an average event, energy deposit from:
Ionization loss of charged particles ~ 2.5 keV
TR photon > 5 keV.
(Photon emission spectrum peaks at 10-30keV)*

Summary

- The field of Particle Identification Detectors is an evolving field.
- They have contributed to some of the important discoveries in High Energy Physics in the last 50 years and they continue to be a crucial part of some of the current Accelerator based experiments and Astro Physics experiments.
- The RICH detectors offer excellent Particle Identification capability for the hadrons since they can be designed to have very good single photon Cherenkov Angle resolution and large Photoelectron yield. Recent advances in photodetectors enhance the capability of these detectors.
- The particle ID using dE/dx , time-of-flight and Transition Radiation detectors continue to provide Particle Identification in different experiments.

Acknowledgement: Thanks to all the authors of the papers from which the material for this Lecture has been compiled.

For information on Cherenkov detectors: (1) <http://pdg.lbl.gov>

(2) T. Ypsilantis et.al. Nucl. Inst. Mech A (1994) 30-51

The Lord of the Rings

Photons from ice and sea under the sky,

Photons from vast water tanks in halls of stone,

Photons from the atmosphere in an insect's eye,

Photons from aerogels, light, clear, blown,

Photons from liquids, gases, crystals flying by,

Photons from fused silica expanding on a cone.

In RICH detectors where PID truths lie.

One Ring to rule them all, One Ring to find them,

One Ring to bring them all, correlate, and bind them

In RICH detectors where PID truths lie.

(From B.N.Ratcliff, Nucl. Inst. Mech. A 501(2003) 211-221)

Cherenkov Detectors in Astro Particle Physics

Goal: Contribute to the understanding of our Universe.

- ❖ Understanding production mechanism ('cosmic accelerators') of HE cosmic rays ;
- ❖ Study very energetic galactic / extragalactic objects : SN remnants, microquasars, GRB, AGN, ...;
- ❖ Search for Dark matter (wimps)
- ❖ . . .

SNR



AGN

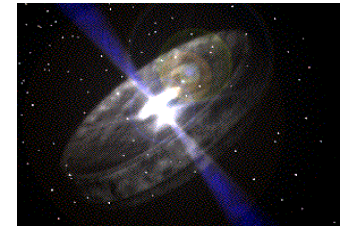

GRB



Micro-
quasars

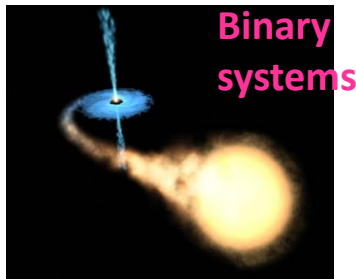

Binary
systems

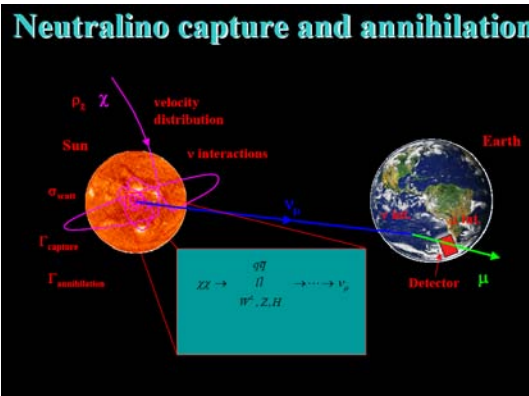

Astro Particle Physics

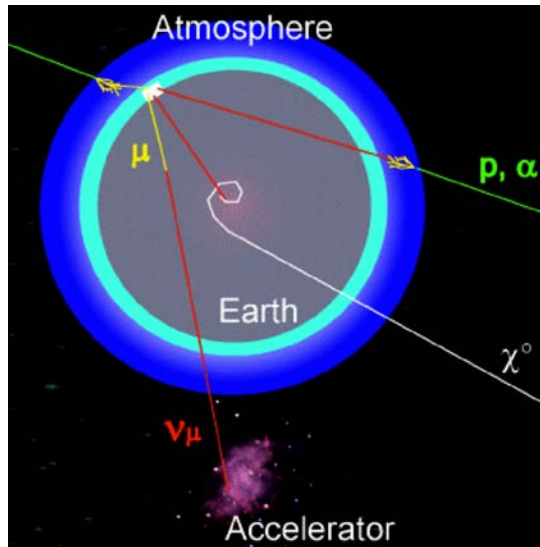

Search for :

- Neutrinos → muons
- High energy Gamma and other Cosmic rays → Air showers
- Ultra high energy Gamma ($> 10^{19}$ eV) → Air showers

Neutrinos: Advantages:

- Neutral : Hence Weak interaction only
- Neutrinos point back to the astrophysical production source
 - Unlike photons which interact with CMB and matter...
 - or protons: which also undergo deflection by magnetic fields

Disadvantages:

- Rate of arrival very low. Hence need very large detectors.
- Using the Ocean , ice in Antartica etc.

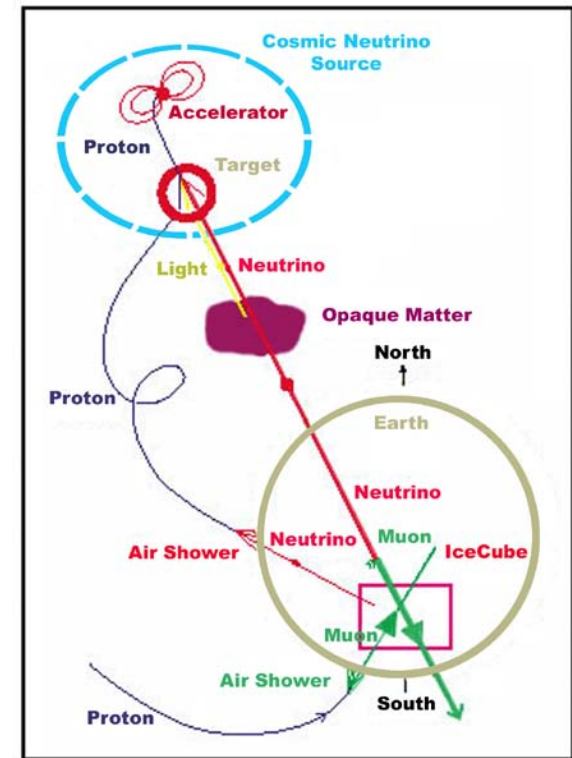

Neutrino Detection

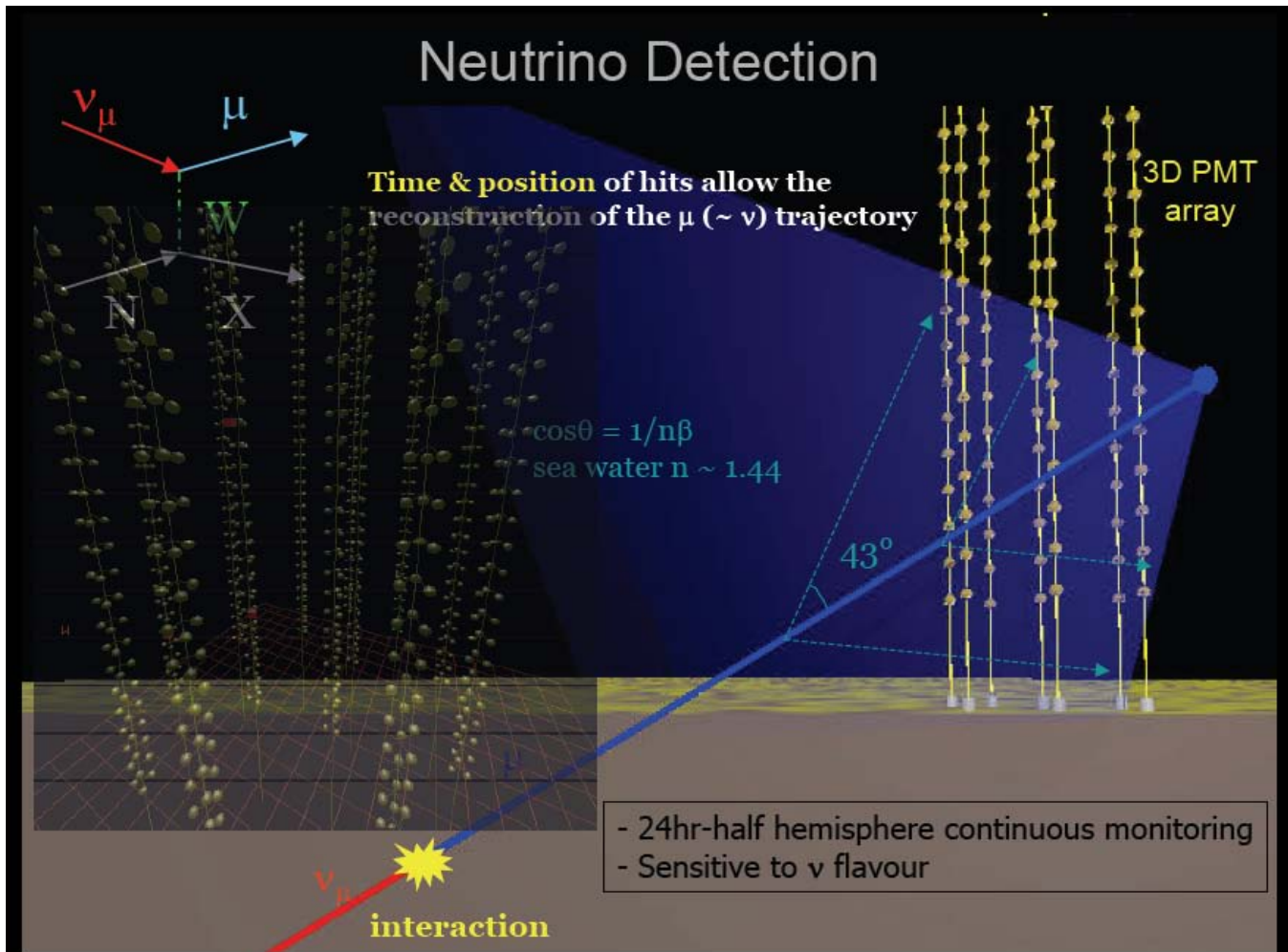

• Typically 1γ / PMT
40 m from μ axis

• Measure position and time of the hits.

Angle between the μ and ν direction=

$$\theta \leq \frac{1.5 \text{ deg.}}{\sqrt{E_\nu [\text{TeV}]}}$$

Importance of Timing Resolution

c in water ~ 20 cm/ns

Chromatic dispersion ~ 2 ns (40 m typ. Path)

(PMT TTS $s \sim 1.3$ ns) so detector not dominant source of error

ANTARES Experiment in the sea.

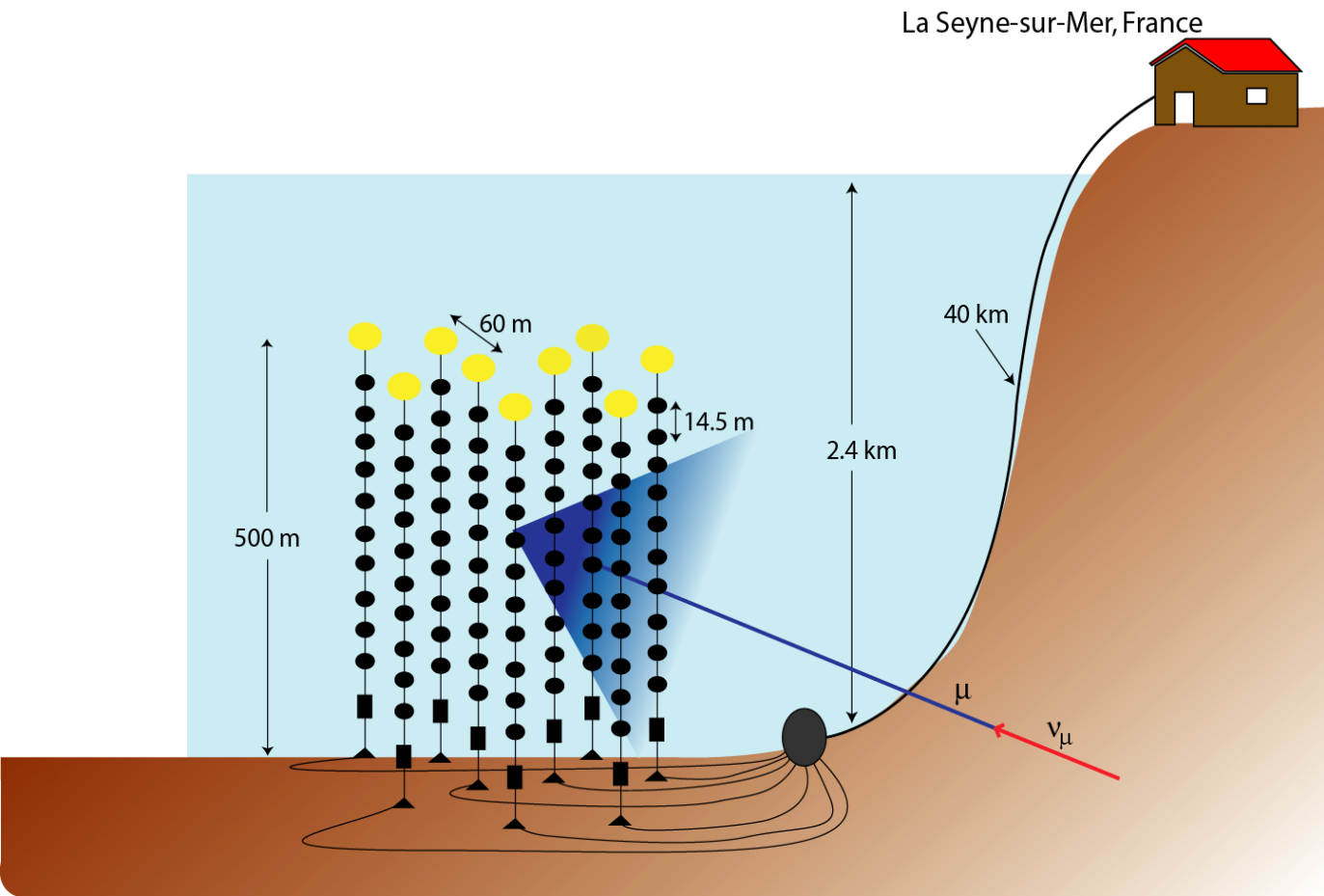

Optical Module

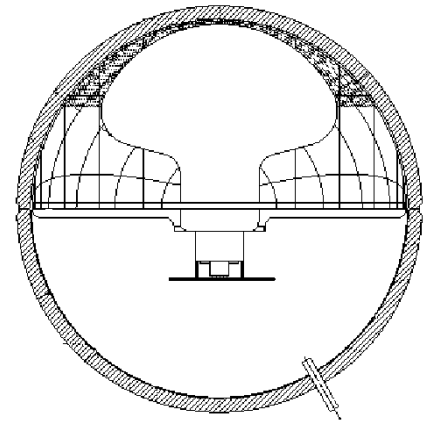

Hamamatsu PMT :
Size :10 inch



Glass pressure Sphere.

IceCube Experiment in Antarctica

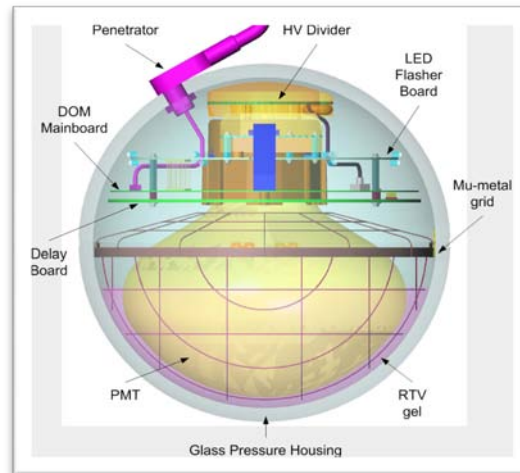
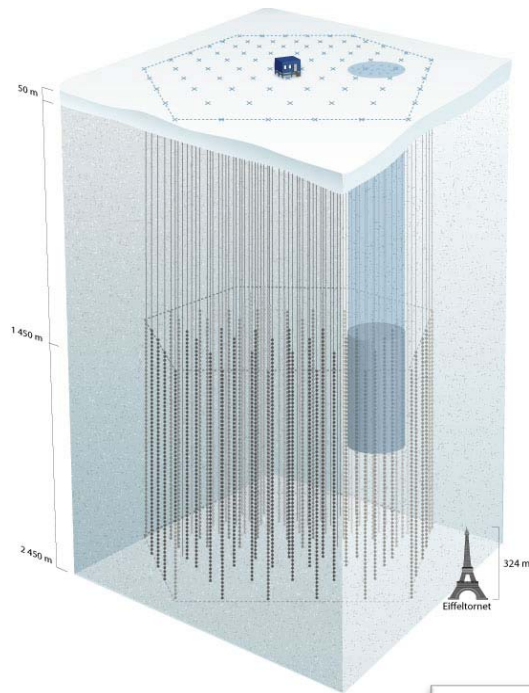

Design Specifications

- Fully digital detector concept.
 - Number of strings – 75
 - Number of surface tanks – 160
 - Number of DOMs – 4820
 - Instrumented volume – 1 km³
 - Angular resolution of in-ice array < 1.0°
-
- Fast timing: resolution < 5 ns DOM-to-DOM
 - Pulse resolution < 10 ns
 - Optical sens. 330 nm to 500 nm
 - Dynamic range
 - 1000 pe / 10 ns
 - 10,000 pe / 1 us.
 - Low noise: < 500 Hz background
 - High gain: O(10⁷) PMT
 - Charge resolution: P/V > 2
 - Low power: 3.75 W
 - Ability to self-calibrate
 - Field-programmable HV generated internal to unit.
 - 10000 psi external

Ice Cube/AMANDA Event signatures

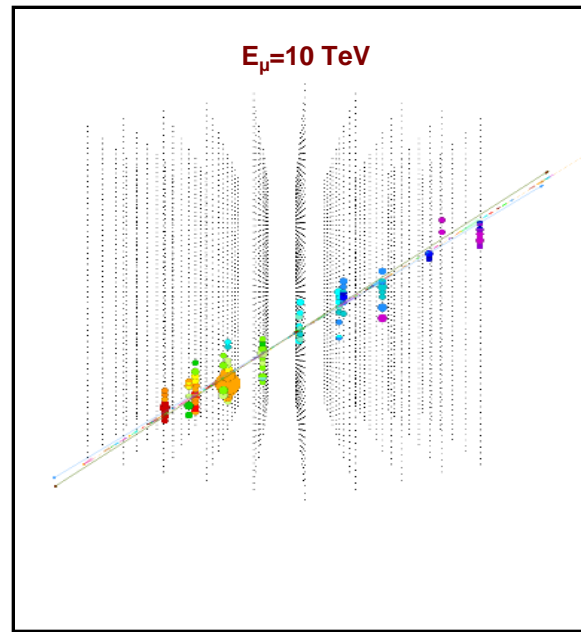
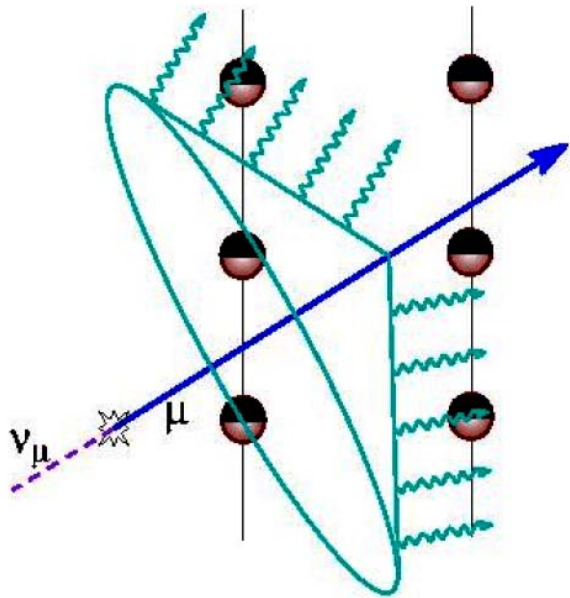

ν_μ from CC interactions

All signals from Cherenkov Radiation.

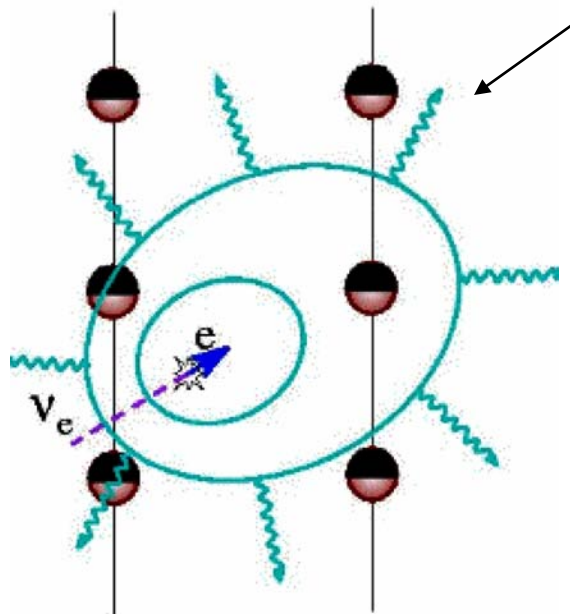

ν_e from CC or ν_x from NC interactions

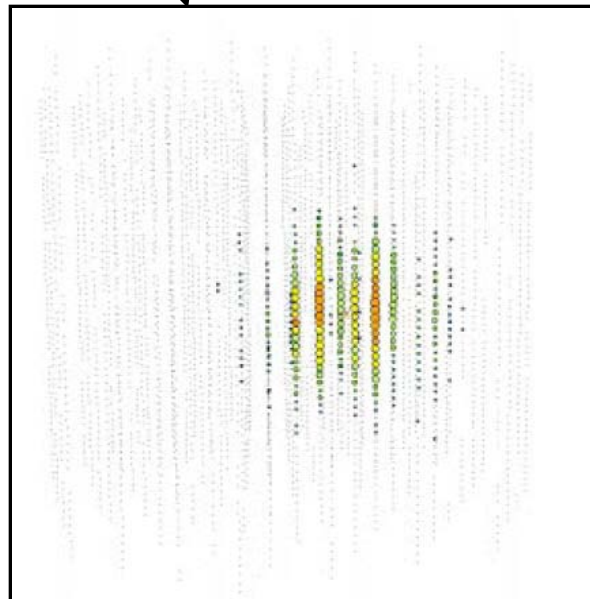

$\nu_\tau \rightarrow \tau \rightarrow \mu$

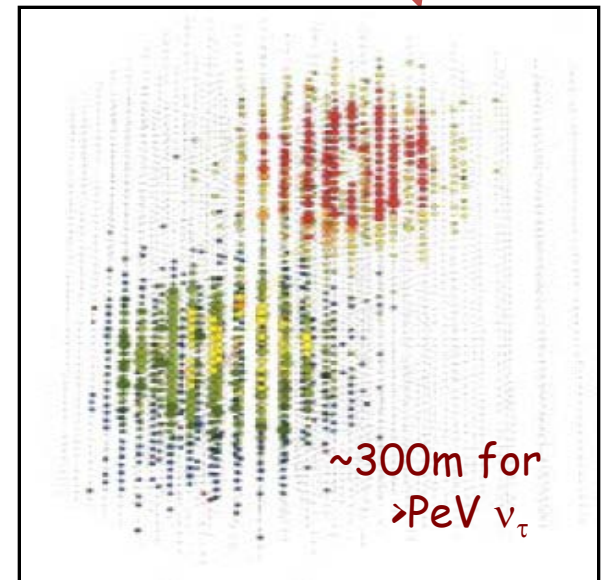

EXTRA SLIDES

DIRC PRINCIPLE

- If $n > \sqrt{2}$ some photons are always **totally internally reflected** for $\beta \approx 1$ tracks.
- **Radiator and light guide**: Long, rectangular **Synthetic Fused Silica** (“Quartz”) bars (*Spectrosil*: average $\langle n(\lambda) \rangle \approx 1.473$, radiation hard, homogenous, **low chromatic dispersion**)
- Photons exit via wedge into **expansion region** (filled with 6m^3 pure, de-ionized water).
- Pinhole imaging on **PMT array** (bar dimension small compared to standoff distance). (10,752 **traditional PMTs ETL 9125**, immersed in water, surrounded by hexagonal “light-catcher”, transit time spread $\sim 1.5\text{nsec}$, $\sim 30\text{mm}$ diameter)
- **DIRC is a 3-D device**, measuring: x , y and **time** of Cherenkov photons, defining θ_c , ϕ_c , $t_{\text{propagation}}$ of photon.

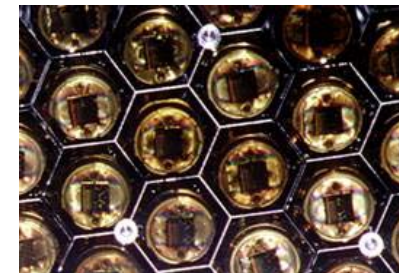
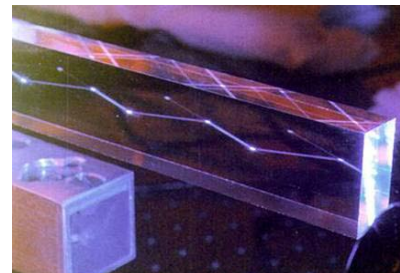
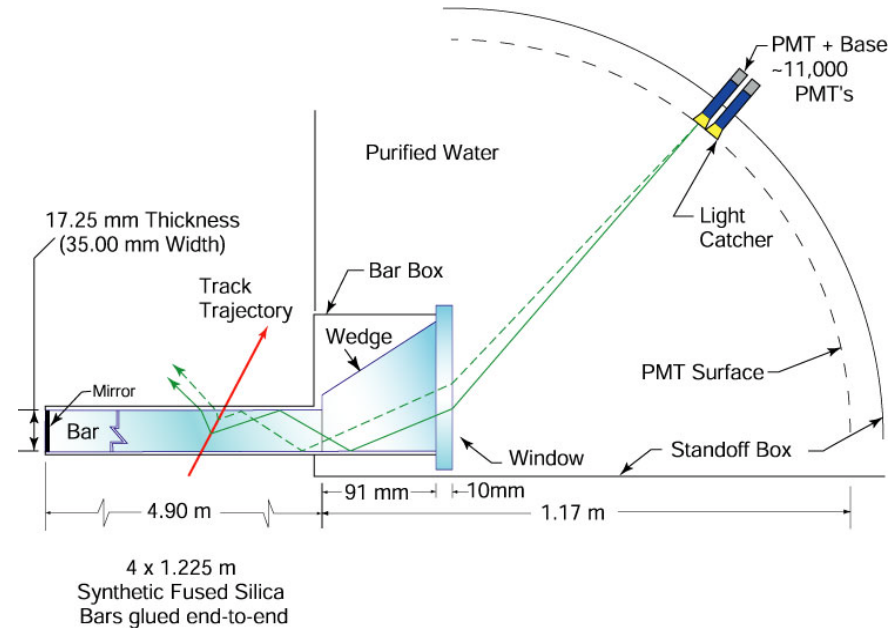

DIRC PERFORMANCE

Number of Cherenkov photons
per track (di-muons) vs. polar angle:

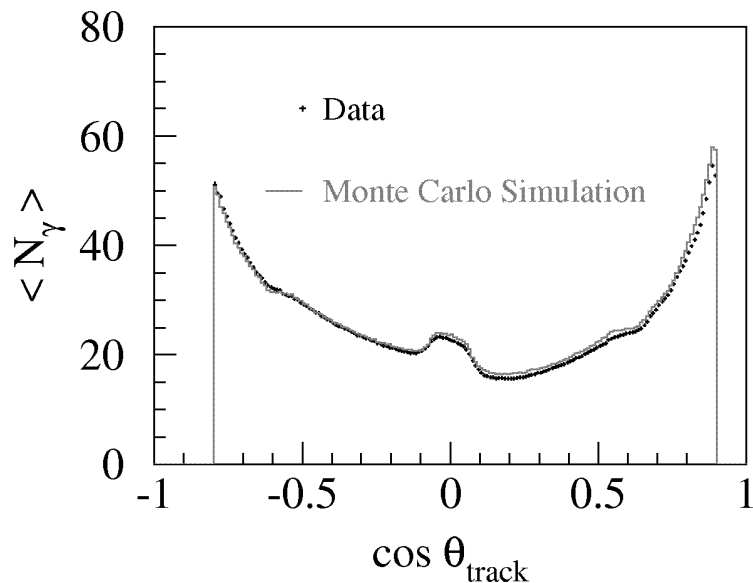

Between 20 and 60 signal photons per track.

Resolution of Cherenkov angle fit
per track (di-muons):

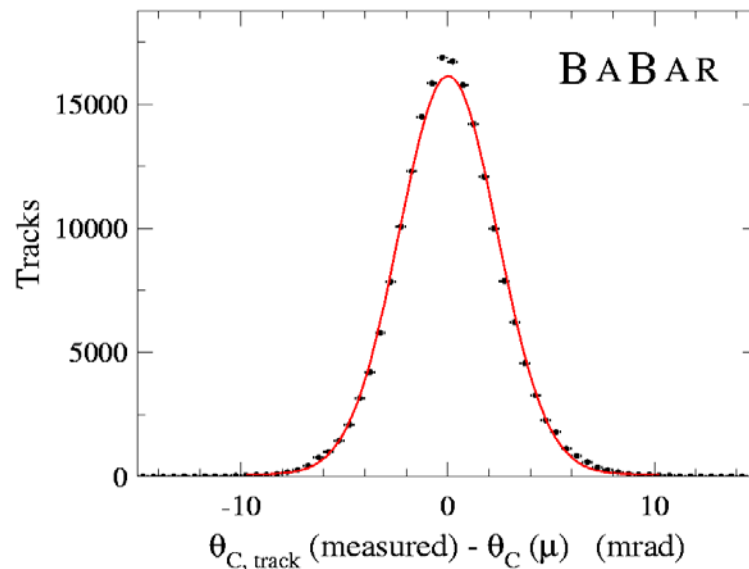

$$\sigma(\Delta\theta_c) = 2.4 \text{ mrad}$$

Track Cherenkov angle resolution is
within $\sim 10\%$ of design

DIRC PERFORMANCE

Kaon selection efficiency typically above 95% with mis-ID of 2-10% between 0.8-3 GeV/c.

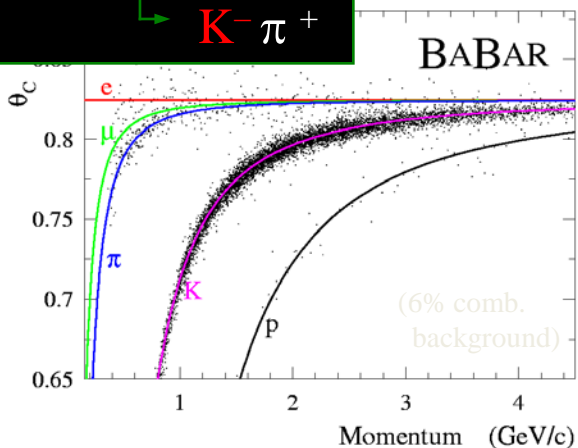

Kaon selection efficiency for $\mathcal{L}^K > \mathcal{L}^\pi$

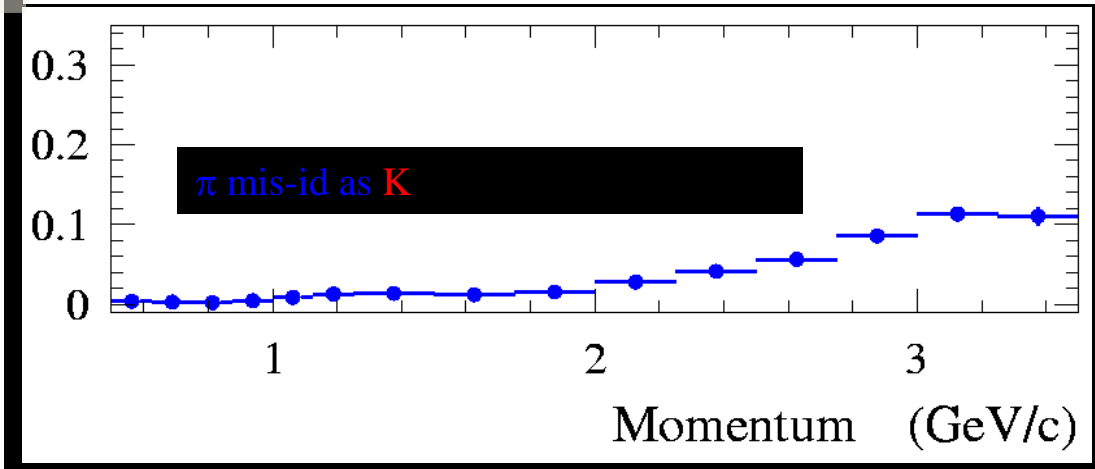
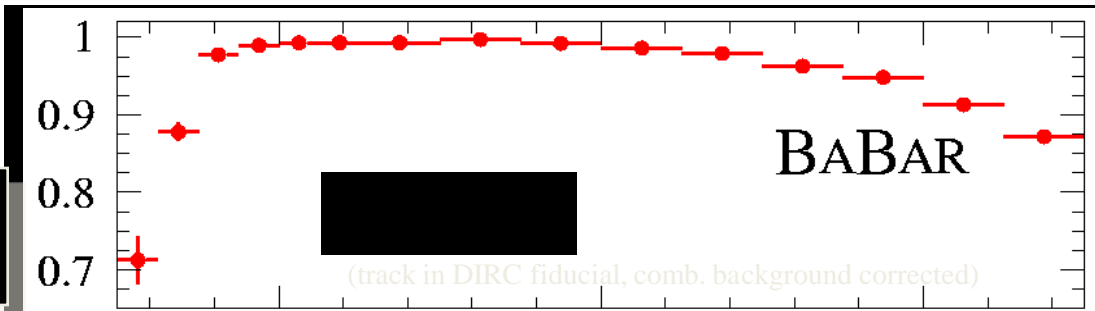
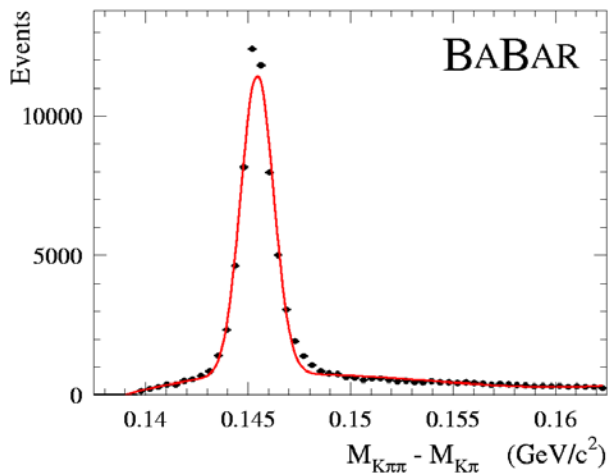

New Development: Focussing DIRC

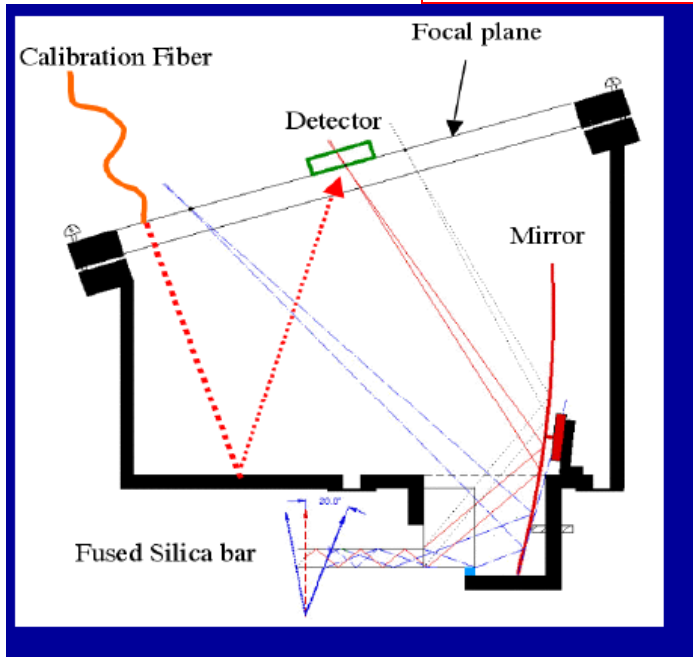

$$v_{\text{group}}(\text{red}) > v_{\text{group}}(\text{blue})$$

- Red photons arrive before blue photons
- Time of Propagation = PathLength / v_{group}
- Correct for Chromatic error from the measurement of time of propagation.

→ Future DIRC needs to be smaller and faster:

Focusing and smaller pixels can **reduce the expansion volume by a factor of 7-10**

Faster PMTs reduce sensitivity to background.

Additional benefit of the faster photon detectors:

- Timing resolution improvement: $\sigma \sim 1.7\text{ns}$ (BABAR DIRC) $\rightarrow \sigma \leq 150\text{ps}$ ($\sim 10\text{x}$ better)
which allows measurement of photon color to correct the chromatic error of θ_c
(contributes $\sigma \sim 5.4$ mrad in BABAR DIRC)

Focusing mirror effect:

- Focusing eliminates effect of the bar thickness (contributes $\sigma \sim 4$ mrad in BABAR DIRC)
- However, the spherical mirror introduces an aberration, so its benefit is smaller.

Ref: NIMA 595(2008)104-107

High Energy Cosmic Ray Spectrum.

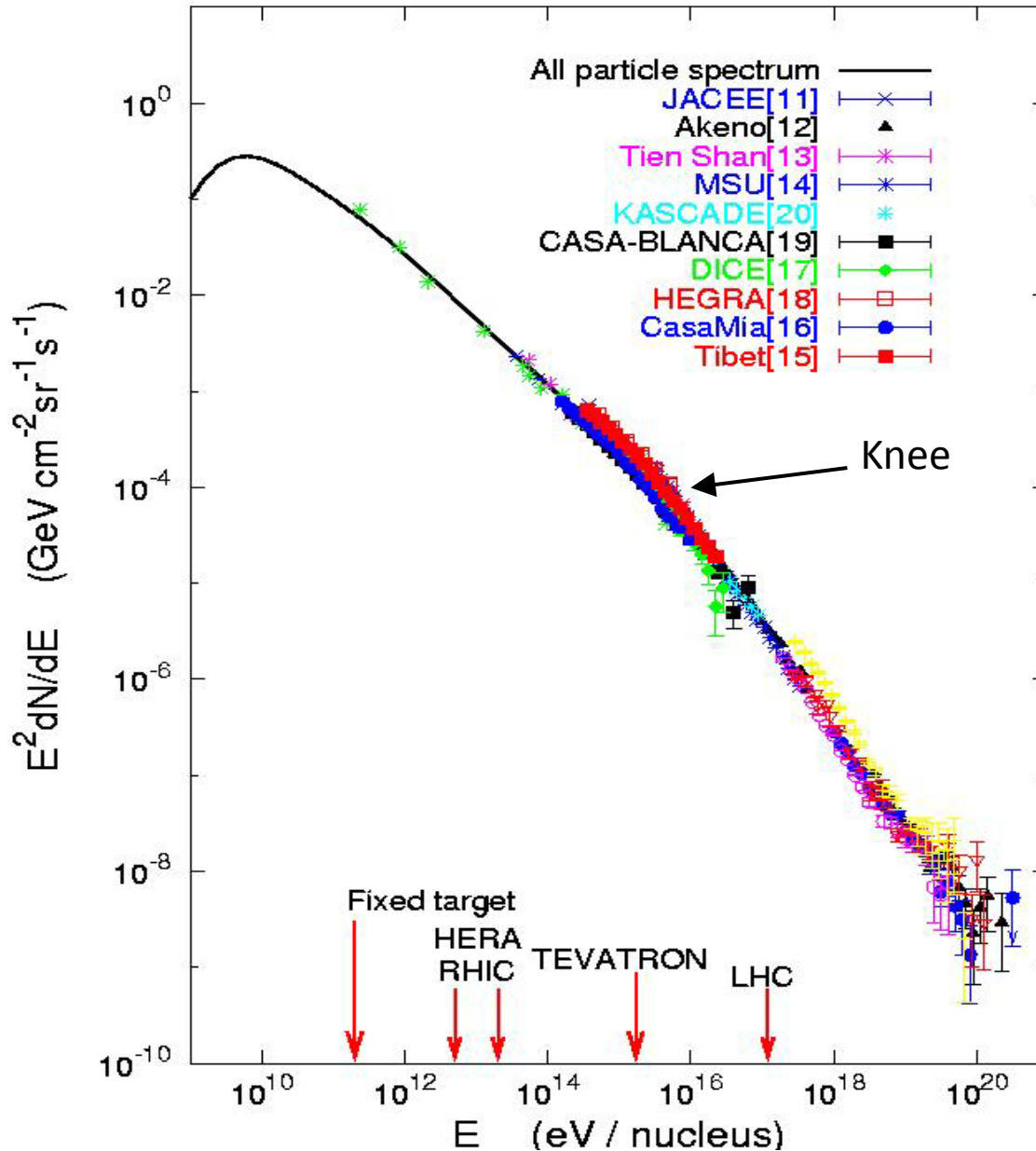

- Measure the Energy Spectrum
- Determine the Arrival Direction distribution etc.
- Composed of Baryons, photons, neutrinos etc.

$>10^{19}$ eV
 $1 \text{ km}^{-2} \text{ year}^{-1} \text{ sr}^{-1}$

Principle of Auger Project

Fluorescence →

**Array of water
Cherenkov detectors** →

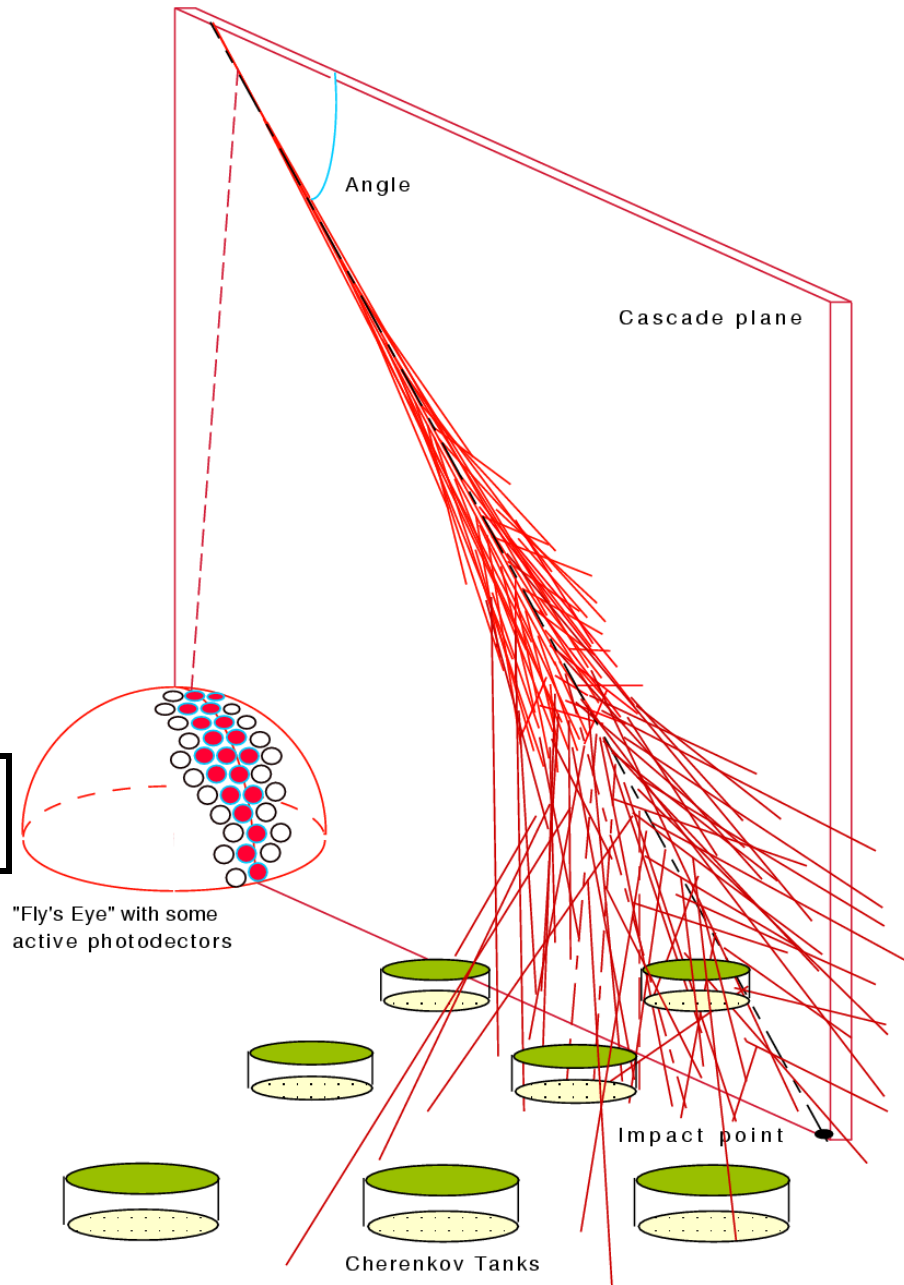

The Pierre Auger Observatory

38° South, Argentina, Mendoza,
Malargue 1.4 km altitude, 850

Argentina
Australia
Bolivia*
Brasil
Czech Republic
France
Germany
Italy
Poland
Mexico
Slovenia
Spain
United Kingdom
USA
Vietnam*



- 1600 surface stations
1.5 km spacing
over 3000 square kilometers
- Fluorescence Detectors:
4 Telescope enclosures,
each with 6 telescopes.

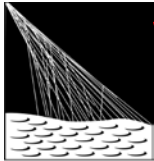

**PIERRE
AUGER
OBSERVATORY**

AUGER Project: Water Cherenkov Detector

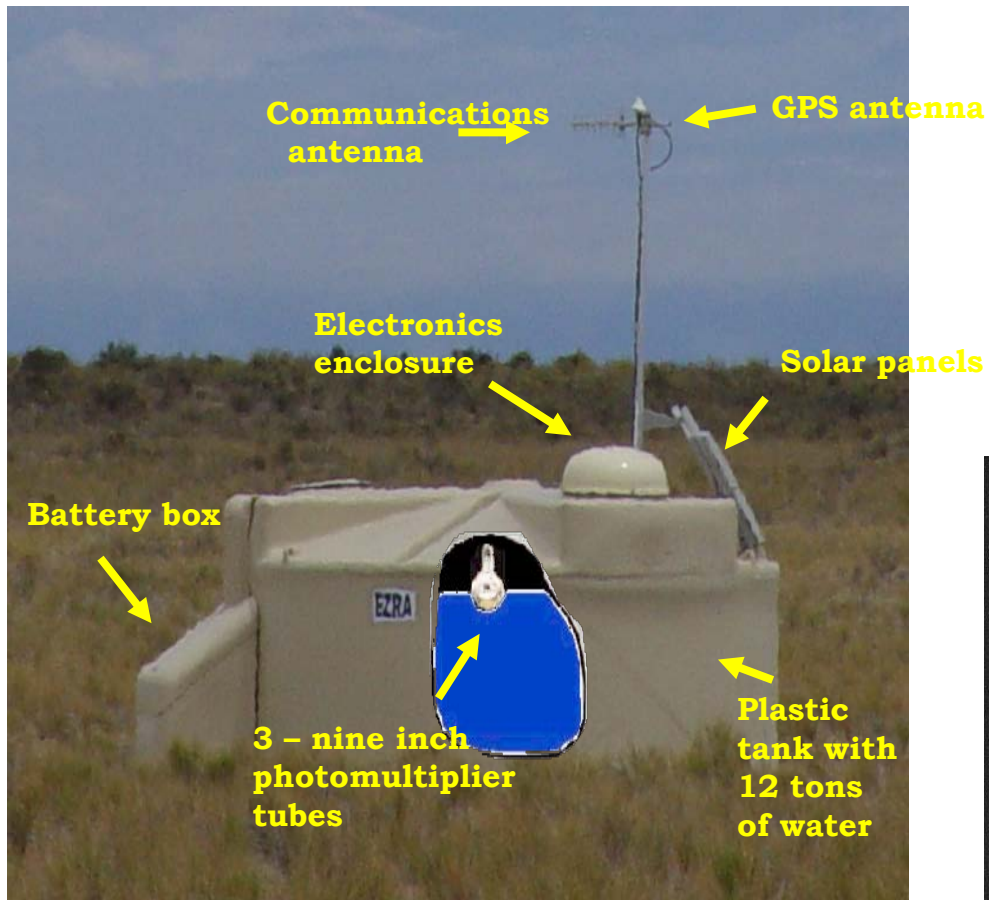

Time difference between
test signals from nearby detectors
(Carmen-Miranda)

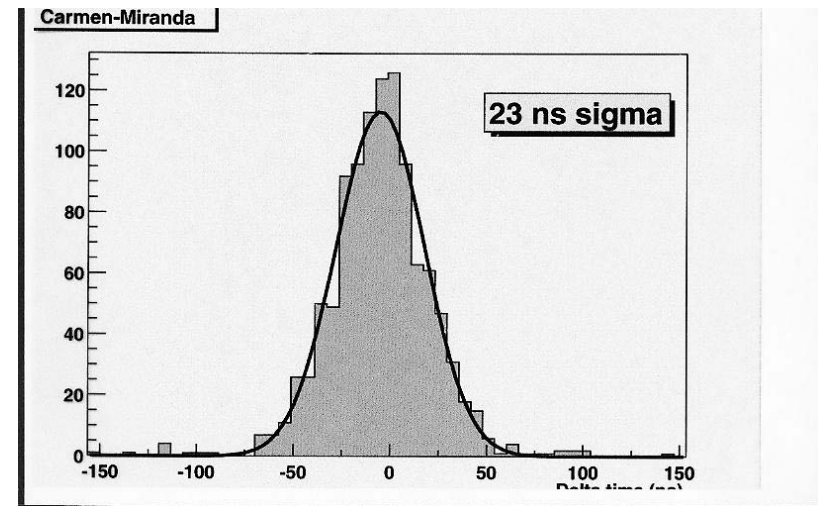

- Installation of the Cherenkov detectors are continuing and data taking started.
- First set of results are published

LHCb Pattern Recognition

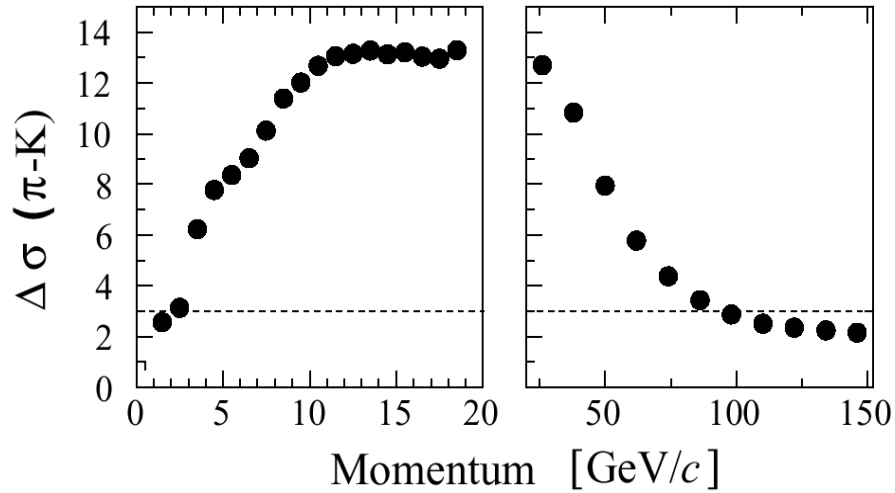

Particle Identification using
the likelihood method.
(From Simulations)

Energy loss by muons dE/dx : Bethe-Block Formula

$$-\frac{dE}{dx} (\text{eV cm}^2 \text{g}^{-1}) = Kq^2 \frac{Z}{A\beta^2} \left[\frac{1}{2} \ln \frac{2m_e c^2 \beta^2 \gamma^2 T_{\max}}{I^2} - \beta^2 - \frac{\delta(\beta\gamma)}{2} \right]$$

Ionisation Constant for material

Density correction

$$T_{\max} \approx 2m_e c^2 \beta^2 \gamma^2$$

Max energy in single Collision.

